

Operating Instructions

HYDROVAR®

HV2.1f – HV3.11f



HV3.15e – HV3.22e



HV3.30e-HV3.45e



Index

1 Important safety instructions	5
2 System Design	8
2.1 Pressure tank	8
3 Technical Data	9
4 Dimensions and Weights	12
5 Mechanical mounting of the HYDROVAR unit on the motor	16
5.1 Included mounting material	16
5.2 Optional components	16
5.2.1 Fittings.....	16
5.2.2 Bus interface.....	17
5.2.3 Sensors (4-20mA).....	17
5.2.4 Filter.....	17
5.2.5 Motor cables for direct-installation.....	17
5.3 Assemble Instruction	18
6 Electrical installation and wiring	22
6.1 Means of protection	22
6.2 EMC-electromagnetic compatibility	23
6.3 Wiring and connections	25
6.3.1 Main Voltage Terminals.....	26
6.3.2 Motor connection.....	28
6.3.3 Control Terminals.....	29
6.3.3.1 Connection examples.....	31
6.4 Selection of the switching-frequency	34
6.5 Reduction of the maximum output current	34
6.6 RFI - switch	35
7 Programming	36
7.1 Display – control panel	36
7.2 Function of the push buttons	37
7.3 Language Selection	37
8 Parameters of the main menu	38
9 Parameters of the Secondary Menu	42
9.1 JOG-MODE	42
9.2 Window	43
9.3 Ramp Hysteresis	43
9.4 Ramp 1: Fast acceleration time	44

9.5 Ramp 2: Fast deceleration time	44
9.6 Ramp 3: Slow acceleration time	44
9.7 Ramp 4: Slow deceleration time	44
9.8 Maximum Frequency	45
9.9 Minimum Frequency	45
9.10 Operation at minimum frequency	46
9.11 Delay time to shut off below minimum frequency	46
9.12 Boost	46
9.13 Sensor – Adjust	47
9.14 Sensor - Curve	47
9.15 Setting of the sensor range	47
9.16 Operation Mode	48
9.17 Regulation mode	49
9.18 Start Value	49
9.19 2nd Required Value	50
9.20 Configuration of the pump running relay (X2/4-5-6)	51
9.21 Submenu Offset	51
9.21.1 Source of the Offset input	51
9.21.2 1 st Offset level.....	52
9.21.3 2 nd Offset level.....	52
9.21.4 Intensity 1.....	52
9.21.5 Intensity 2.....	52
9.21.6 Example for the Offset.....	53
9.22 Submenu Sequence control	54
9.22.1 Lift Value (actual value increase).....	54
9.22.2 Fall Value (actual value decrease).....	54
9.22.3 Enable sequence control.....	55
9.22.4 Switch Interval.....	55
9.22.5 Source of required value.....	55
9.22.6 Submenu Synchronous Control	56
9.22.6.1 Synchronous Limit	56
9.22.6.2 Synchronous Window.....	56
9.22.7 Pump status indication	57
9.22.8 Busarbit-Diag. - Counter for interface communication problems	57
9.23 Submenu - RS 485 Interface	58
9.23.1 Pump Address.....	58
9.23.2 ADC Reference.....	58
9.24 Frequency Lifting	59
9.25 Lift- Amount (Intensity)	59
9.26 Analogue - Output	60
9.27 Dimension Unit	60
9.28 Automatic test run	60
9.29 Submenu for manual test run	61

9.29.1 Activate manual test run.....	61
9.29.2 Test Frequency.....	61
9.29.3 Boost for manual test run.....	61
9.30 Submenu - Error	62
9.30.1 Conveyor Limit.....	62
9.30.2 Delay Time.....	62
9.30.3 Automatic Error reset	62
9.30.4 Clear Errors.....	62
9.31 Operating Hours.....	63
9.32 Display – Contrast	63
9.33 Set Password.....	63
9.34 Lock Function	63
9.35 Internal Heater	63
9.36 Setting Default Values	64
9.36.1 Default Values Europe	64
9.36.2 Default Values USA.....	64
9.37 Saving.....	64
10 Error Signals.....	65
11 RS 485 - Interface.....	69
12 Auxiliary Texts.....	69
13 Maintenance	69

Follow the Pump Operating and Maintenance Instructions
We reserve the right to alter specifications

1 Important safety instructions

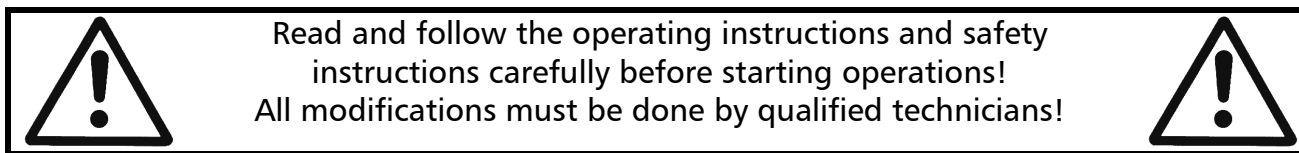

Warns that failure to observe the precaution may cause electric shock



Warns that failure to observe the precaution may cause personal injury or damage to property.

In addition to the instructions contained in these operating instructions please pay attention to universal safety and accident prevention regulations.

Basically the HYDROVAR must be disconnected from the power supply before any work can be carried out in the electrical or mechanical part of the system.

Installation, maintenance and repair work may only be carried out by trained, skilled and qualified personnel.

Unauthorized modifications or changes to the system make all guarantees null and void.

During operation, the motor can be stopped by open a digital input or manually operated, whereby the HYDROVAR and the motor remain under voltage. For safety reasons, the HYDROVAR has to be disconnected from the power supply when carrying out work on the machinery.



When the HYDROVAR is connected to power supply, the components of the power unit as well as certain components of the master control unit are also connected to the power supply.

Touching these components seriously endangers life!

Before removing the HYDROVAR cover the system must be disconnected from the power supply. After switching off the power supply wait **at least 5 minutes** before starting work on or in the HYDROVAR (the capacitors in the intermediate circuit are discharged by the installed discharge resistors first).

Voltages of up to 800 volts are possible (if there are faults it can be higher)

All work, carried out at opened HYDROVAR, may only be performed by qualified and authorized staff.

Furthermore, care must be taken not to short circuit the neighbouring components when connecting the external control wires and that open cable ends which are not in use are isolated.



The HYDROVAR contains electronic safety devices which switch off the control element in the event of faults, whereby the motor has zero current but remains energised and comes to a halt. The motor can also be halted by mechanical blocking. If it is switched off electronically the motor is disconnected from the mains voltage through the electronics of the HYDROVAR but is not potential-free in the circuit.

In addition voltage fluctuations, especially power failures can cause the system to switch off itself.

Repair of faults can cause the motor to start up again!



The system may only be put into operation when it has been grounded. In addition, equipotential bonding of all pipes must be ensured.

The operating instructions must be read, understood and followed by the operating personnel. We point out that we accept no liability for damage and operating disorders which are the result of non-compliance with the operating instructions.



High voltage tests of the HYDROVAR or the motor may damage the electronic components! Hence bridge the in- and outgoing terminals L1 - L2 - L3 - U- V-W before.

To avoid incorrect metering by capacitors incorporated in the electronic part isolate the motor from the HYDROVAR.

Transport, Handling, Storage, Disposal:

- Check the HYDROVAR immediately upon delivery/receipt of dispatch for damage or missing parts
- The HYDROVAR unit must be transported carefully and by competent personnel.
- Avoid serious impacts

NOTICE!



The use of the WEEE-Symbol indicates that this product may not be treated as household waste.

Dispose of all packing materials and the unit in accordance with local regulations.

For more detailed information about the recycling of this product, please contact your local authority, your household waste disposal service provider or the shop where you purchased the product.

CAUTION!



Lifting aids (stacker, crane, crane mounting device, lifting blocks, sling ropes, etc.) must have the proper dimensions so that they can bear the weight of the HYDROVAR.

CAUTION!



It is not allowed to carry the HYDROVAR around by using the connected cables.

Do not damage the cable during transport (do not squeeze, bend or drag). The cable ends must be kept dry.

WARNING!



- Do not stand underneath suspended loads
- take note of the general regulations on prevention of accidents
- The HYDROVAR must be secured against tipping over and slipping until it has been fixed in its final location.

2 System Design

The following diagrams show typical single pump and multi-pump systems using the HYDROVAR control unit. Connection can be made directly to a water supply. In such a case, a pressure switch on the suction side should be used.

Single Pump Layout

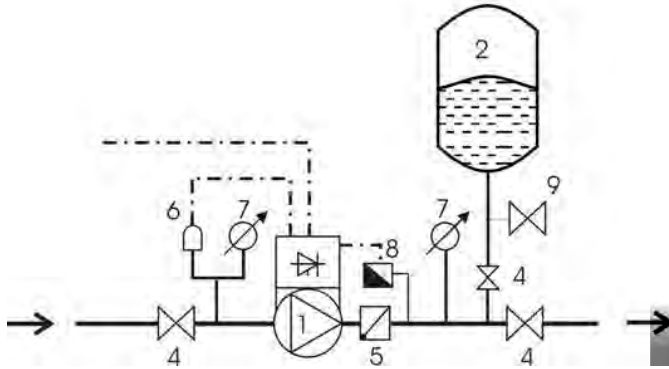

Multi Pump Layout

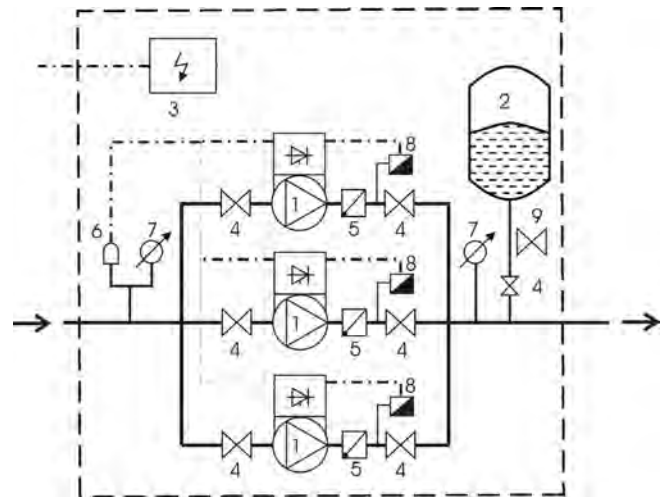

- (1) pump with HYDROVAR
- (2) diaphragm tank
- (3) distribution panel

- (4) gate valve
- (5) non return valve
- (6) low water control

- (7) pressure gauge
- (8) pressure transmitter
- (9) drain tap

2.1 Pressure tank

A diaphragm pressure tank is used on the discharge side of the pump to maintain pressure in the line when there is no demand. This will keep the pumps from continuing to run at zero demand. With the HYDROVAR, it isn't necessary to have a large tank for supply purposes. The tank must be permitted and suitable for systems pressure. The tank should have a capacity of min. 10% of the maximum system flow rate [l/min] of one pump (also valid for multi-pump system).

Example:

Maximum flow rate of the pump = 250 litres per minute

Minimum volume of the tank = $250 \times 0.10 = 25$ litres

The pre-charge pressure of the tank can be determined in the following table:

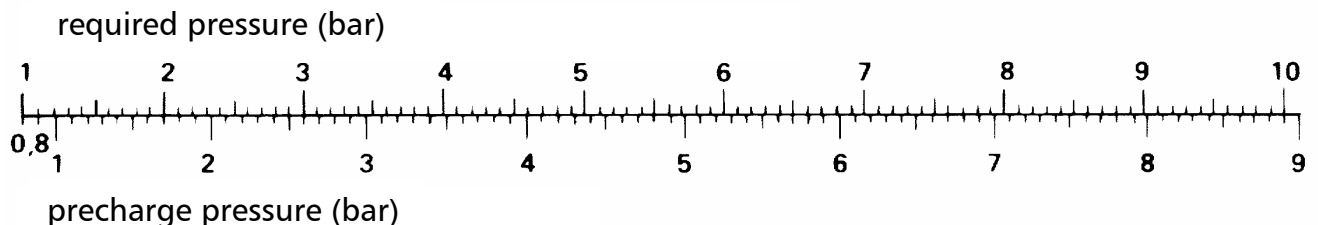

NOTICE: To check and set the right pre-charge pressure, please make the tank pressure less before.

3 Technical Data

HYDROVAR		Power Supply			
Type	Rated output	Voltage limits 48-62 Hz	Rated current input	line protection max.	Maximum connection
HV	[kW]	[V]	[A]	[A]	[mm ²]
2.1f	1,5	1x220-240 -10% +15%	12,7	20	10
2.2f	2,2		16,5	25	
3.2f	2,2	3x380-460 ± 15%	6,3	13	10
3.3f	3		7,4	13	
3.4f	4		9,5	16	
3.5f	5,5	3x380-460 ± 15%	12,6	20	10
3.7f	7,5		16,3	25	
3.11f	11		23,2	32	
3.15e	15	3x380-460 -15% +10%	31,6	40	25
3.18e	18,5		39	50	
3.22e	22		46,3	63	
3.30e	30	3x380-460 -15% +10%	61	80	50
3.37e	37		74,7	100	
3.45e	45		89,5	125	

HYDROVAR		Output to the motor		
Type	Rated Output	Max. Voltage Output	Rated Current output	Motor connection cables
HV	[kW]	[V]	[A]	mm ²
2.1f	1,5	3x U _{in}	7	4x1,5 – 4x4
2.2f	2,2		10	
3.2f	2,2	3x U _{in}	5,7	4x1,5 – 4x4
3.3f	3		7	
3.4f	4		9	
3.5f	5,5	3x U _{in}	13,5	4x2,5 – 4x6
3.7f	7,5		17	
3.11f	11		23	
3.15e	15	3x U _{in}	30	4x6 – 4x25
3.18e	18,5		37	
3.22e	22		43	
3.30e	30	3x U _{in}	58	4x25 – 4x50
3.37e	37		71	
3.45e	45		85	



Make sure that the Hydrovar's electrical data match those of the electric pump. Improper combinations may cause malfunctions and fail to ensure the protection of the electric motor.

The rated current of the motor must be lower than the rated current of the Hydrovar to prevent overheating or shutdown due to "OVERLOAD".

The max. output current of the HYDROVAR could reach 110% of the nominal current for max. 10 sec. before the error "Overload" will occur.

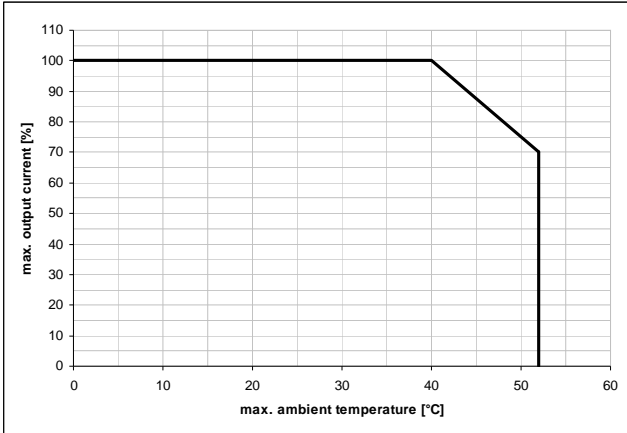
<p>Ambient temperature:</p>	<p>0° C ... +40°C At higher temperatures a reduction of the output current or the use of the next HYDROVAR type is necessary.</p>  <p>○ Protect the HYDROVAR against direct sunlight! ○ Outdoor installation without protection of the HYDROVAR is not permitted!</p>
<p>Storage temperature:</p>	<p>-25° .C ... +55° C (+70°C during max. 24 hours.)</p>
<p>Humidity:</p>	<p>RH max. 50% at 40°C, unlimited RH max. 90% at 20°C, max. 30 days per year 75% average per year (Class F) Condensation is not permitted!</p>
<p>Air pollution:</p>	<p>The air may contain dry dust as found in workshops where there is no excessive quantity of dust due to machines. Excessive amounts of dust, acids, corrosive gases, salts etc. are not permitted</p>
<p>Altitude:</p>	<p>max. 1000m above sea level At sites over 1000 m above sea level, the maximum output power has to be derated by 1% for every additional 100m. If the installation site is higher than 2000 m above sea level, please contact your local distributor.</p>
<p>Class of protection:</p>	<p>HV2.1 - HV3.11f IP 55 (NEMA 4) HV3.15 - HV3.45e IP 54 (NEMA 12)</p>
<p>Certifications:</p>	<p>CE, UL, C-Tick, cUL</p>

The HYDROVAR complies with the general EMC regulations and is tested according to the following standards:

- High Frequency Field Interference ENV 50204
- Electrostatic Discharge EN 61000-4
- Radio interference Suppression
 EN 61000-6-1 (2002)
 EN 61000-6-2 (2002)
 EN 61000-6-3 (2002)
 EN 61000-6-4 (2002)

4 Dimensions and Weights

HV 2.1/2.2/3.2/3.3/3.4 f

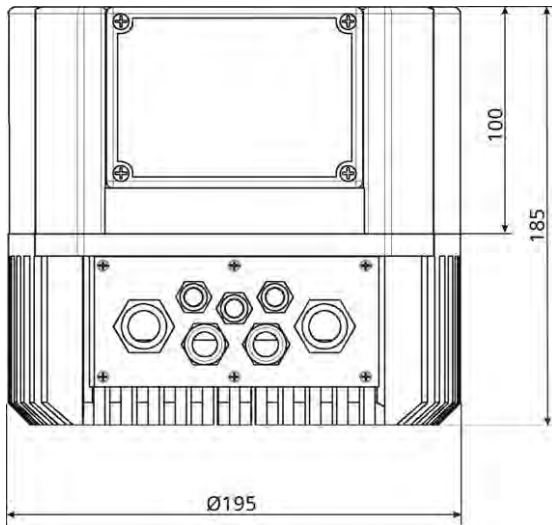

All dimensions in millimetres!

Type	Weight [kg]	HV + WM-Kit [kg]
HV 2.1f	5,80	6,80
HV 2.2f		
HV 3.2f		8,40
HV 3.3f		
HV 3.4f		

Drawings are not in scale!

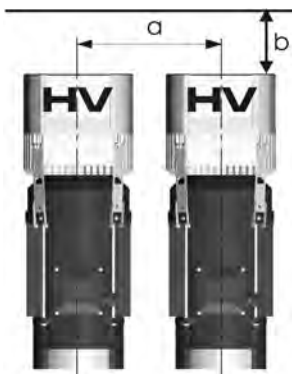

a ... centre-distance between the HYDROVAR	300 [mm]
b ... expansion space for maintenance	120 [mm]

Wall-mounting version:

high: 265 [mm] width: 195 [mm] depth: 195 [mm]

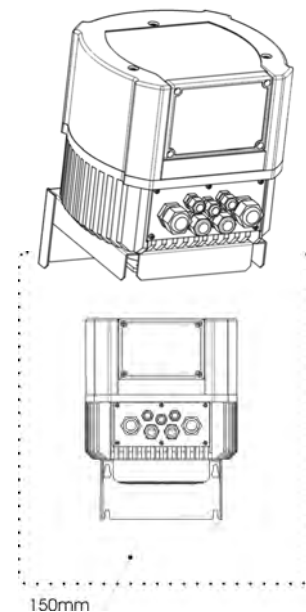
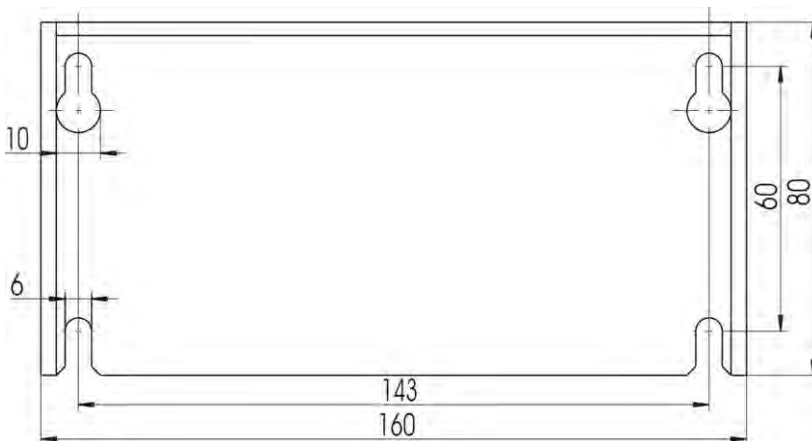

Mounting space around the HYDROVAR:

150 [mm]

HV 3.5/3.7/3.11 f

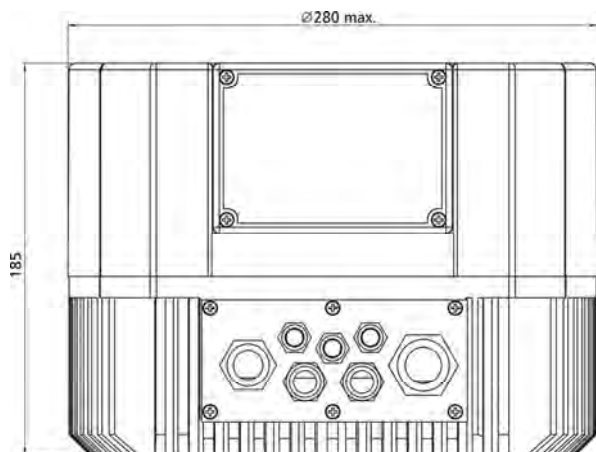

Type	Weight [kg]	HV + WM-Kit [kg]
HV 3.5f	10,00	12,60
HV 3.7f		
HV 3.11f		

All dimensions in millimetres!

Drawings are not in scale!

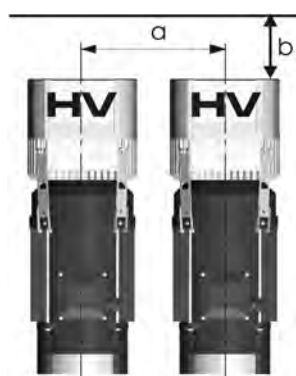

a ... centre-distance between the HYDROVAR	430 [mm]
b ... expansion space for maintenance	120 [mm]

Wall-mounting version:

high: 305 [mm] width: 280 [mm] depth: 280 [mm]

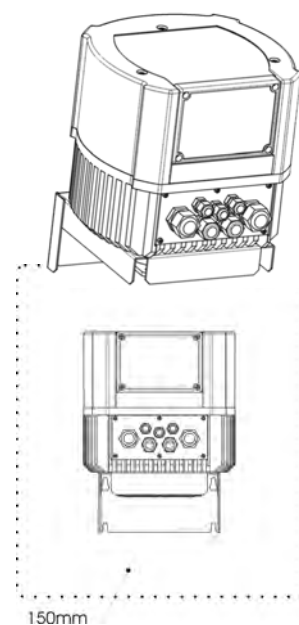
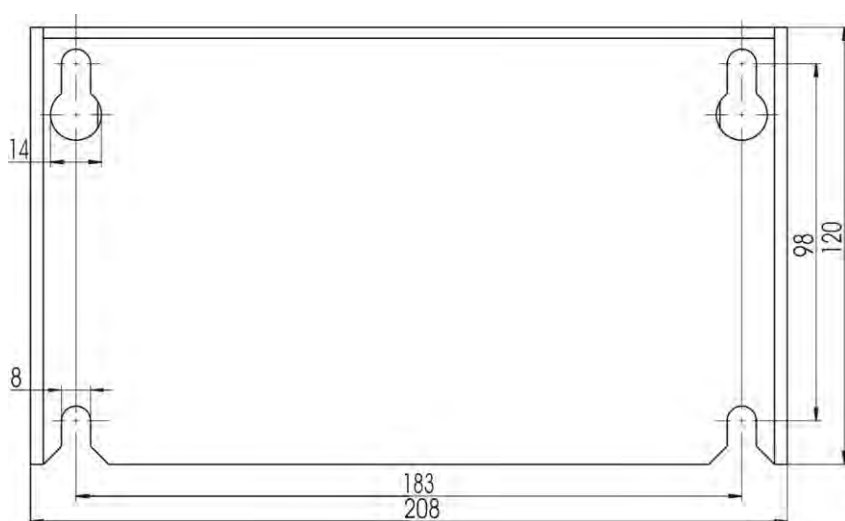

Mounting space around the HYDROVAR: 150 [mm]

HV 3.15/3.18/3.22 e

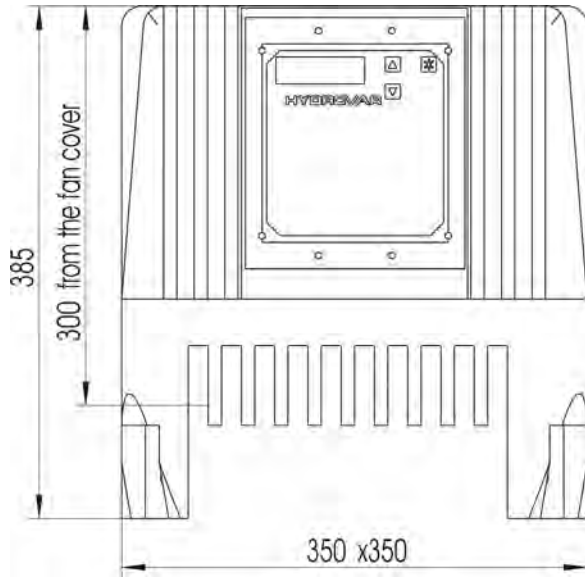

Type	Weight [kg]	HV + WM-Kit [kg]
HV 3.15e	29,00	40,00
HV 3.18e		40,00
HV 3.22e		40,00

All dimensions in millimetres!

Drawings are not in scale!

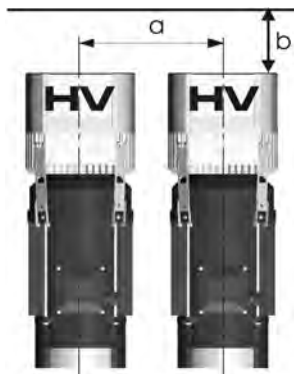

a ... centre-distance between the HYDROVAR	550 [mm]
b ... expansion space for maintenance	300 [mm]
max. diameter of the motor fan cover	385 [mm]

Wall-mounting version:

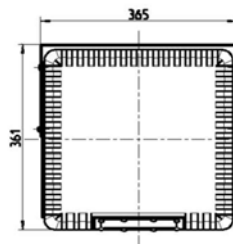
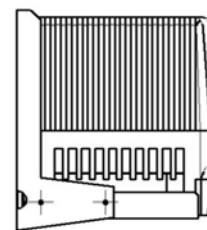
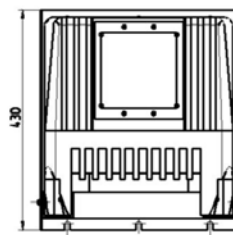
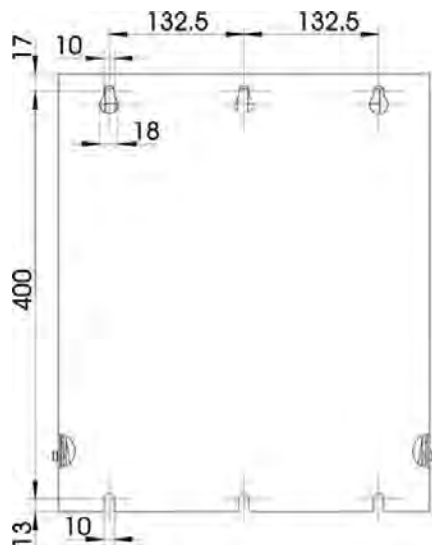

Wall-mounting version	
	[mm]
High	430
wide	365
deep	361

Mounting space: - above: 300 [mm]
 - beside: 200 [mm]
 - below: 150 [mm]

HV 3.30/3.37/3.45 e

Not available as motor-mounted version!

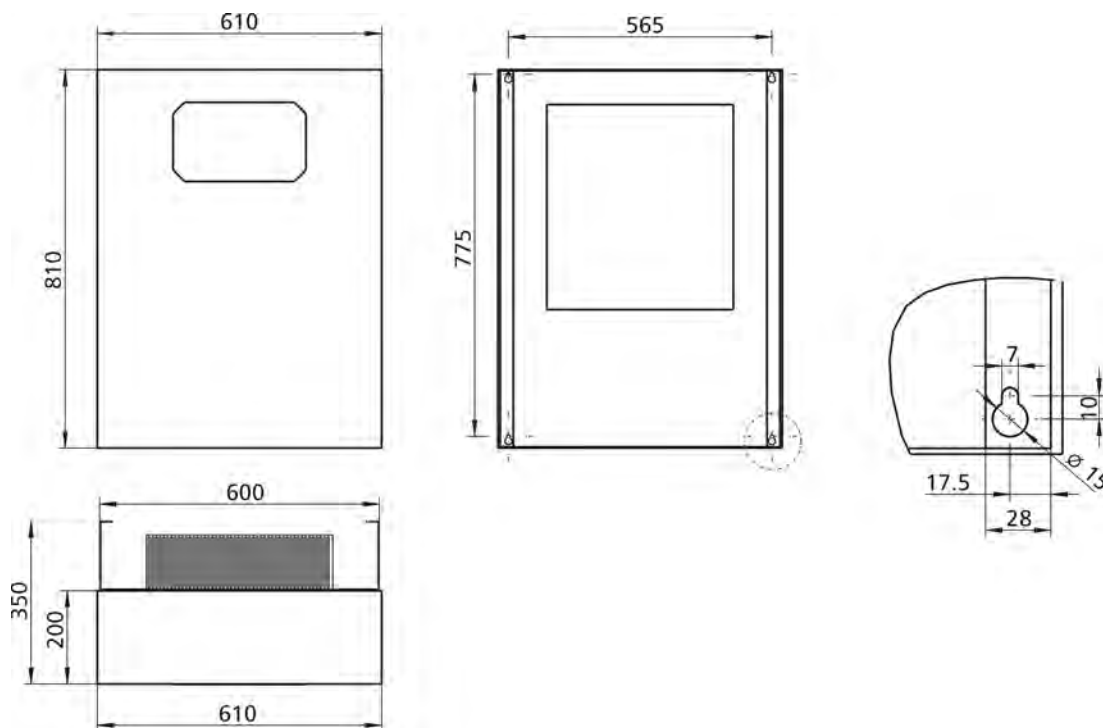

All dimensions in millimetres!
Drawings are not in scale!

Type	Weight [kg]
HV 3.30e	57,00
HV 3.37e	57,00
HV 3.45e	60,00

Mounting space above:
Beside and below the HYDROVAR:

500 [mm]
150 [mm]

5 Mechanical mounting of the HYDROVAR unit on the motor

5.1 Included mounting material

Included components	Cable gland					Cable gland		Closing gland				PTC Motor	Center-piece	Terminals for max. [mm ²]
	M	M	M	M	M	PG	PG	M	M	PG	PG			
	12	16	20	25	40	16	29	12	16	16	29			
Cable diameter [mm]	3,5-7	4,5-10	7-13	9-17	19-28	9-14	14-25							
HV-type														
2.1-3.4 f	2 (3)	2	2					3	1			1	1	10
3.5-3.11 f	2 (3)	2		2				3	1			1	1	10
3.15-3.22 e						0 (2)	1 (2)			1	1	1		25
3.30-3.45 e	2 (3)	2 (2)			2 (2)			3	1			1		50

() max. available cable entries

5.2 Optional components

5.2.1 Fittings

Mounting clamps for motor-mounting

4 pieces per set

(only available for HV 1.15-3.11f)

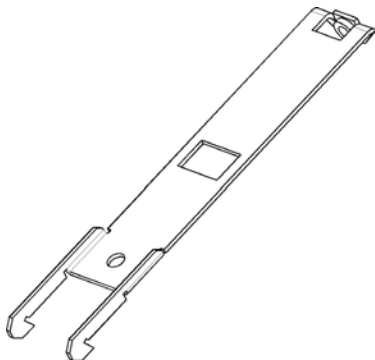

Mounting ring

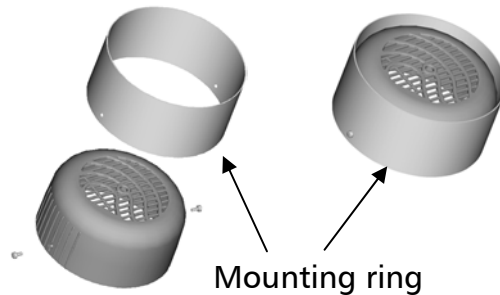

Available for the diameters: 140 mm
155 mm



CAUTION!

If you use a motor with plastic fan cover, you have to use a steel mounting ring.

Distance-bushes

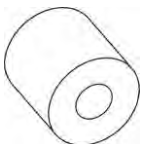

Distance - bushes which are mounted between the HYDROVAR and the motor fan cover. Different bushes are available, which depends to the output and the type of the motor. **(only necessary for the types HV 3.15-3.22e)**

45° Adapter



Available for HV 2.1 – 3.11f

Remote Display



Available for HV 2.1 – 3.11f

5.2.2 Bus interface

MODBUS

for installation in the
HYDROVAR



for external installation
– switching cabinet

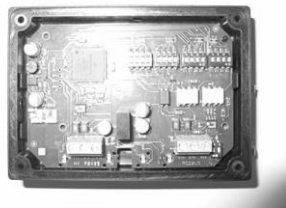

for external installation –
wall mounting



5.2.3 Sensors (4-20mA)

- pressure-transducer
- differential-pressure-transducer
- level-sensor
- temperature-sensor
- flow indicator (orifice plate, inductive flow metering)

5.2.4 Filter

- Motor-coils
- Line-coils
- EMC Filter (see chapter 6.2 EMV)

5.2.5 Motor cables for direct-installation

Available for HV 2.1f – 3.22e

5.3 Assemble Instruction

HV 2.1f – HV 3.11f

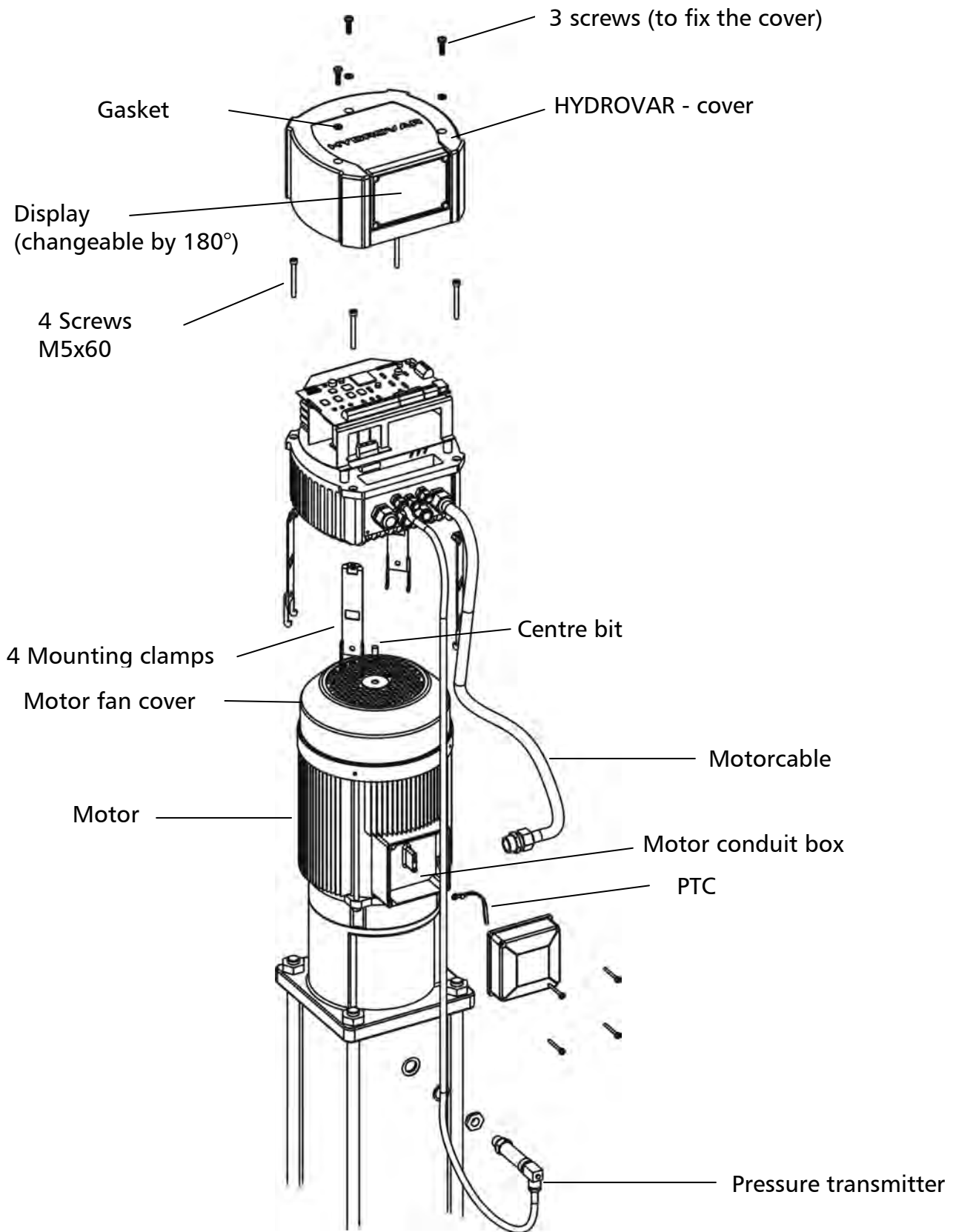

To remove the HYDROVAR – cover, open the 3 fastening screws.

- Be careful not to lose the small gaskets!
- Ensure that there is no water on the unit before you open the cover.
- Be careful not to damage the connecting cable!

- Position the HYDROVAR on the motor fan cover.
- Try to centre it as good as possible using the rubber centre bit.
 - If you use a motor with plastic fan cover, you have to use a steel mounting ring.

- Install the HYDROVAR on the motor fan cover by using the mounting brackets, the four screws and the related washers.
- Make sure the converter is well centred and then tighten the four screws.
- Tighten each fastening screw until the two bottom teeth in the brackets start to grip the fan cover.

- After connecting the electrical components, mount the cover on the HYDROVAR and tighten the three fastening screws.
 - Make sure of a good connection of the connecting cable and the ground wire.
 - Control the gasket of the HYDROVAR and don't forget to install the gaskets of the fastening screws.
 - Ensure that the mounting of the cable glands is done properly and use closing glands for cable-bushings which aren't used.

HV 3.15e – HV 3.22e

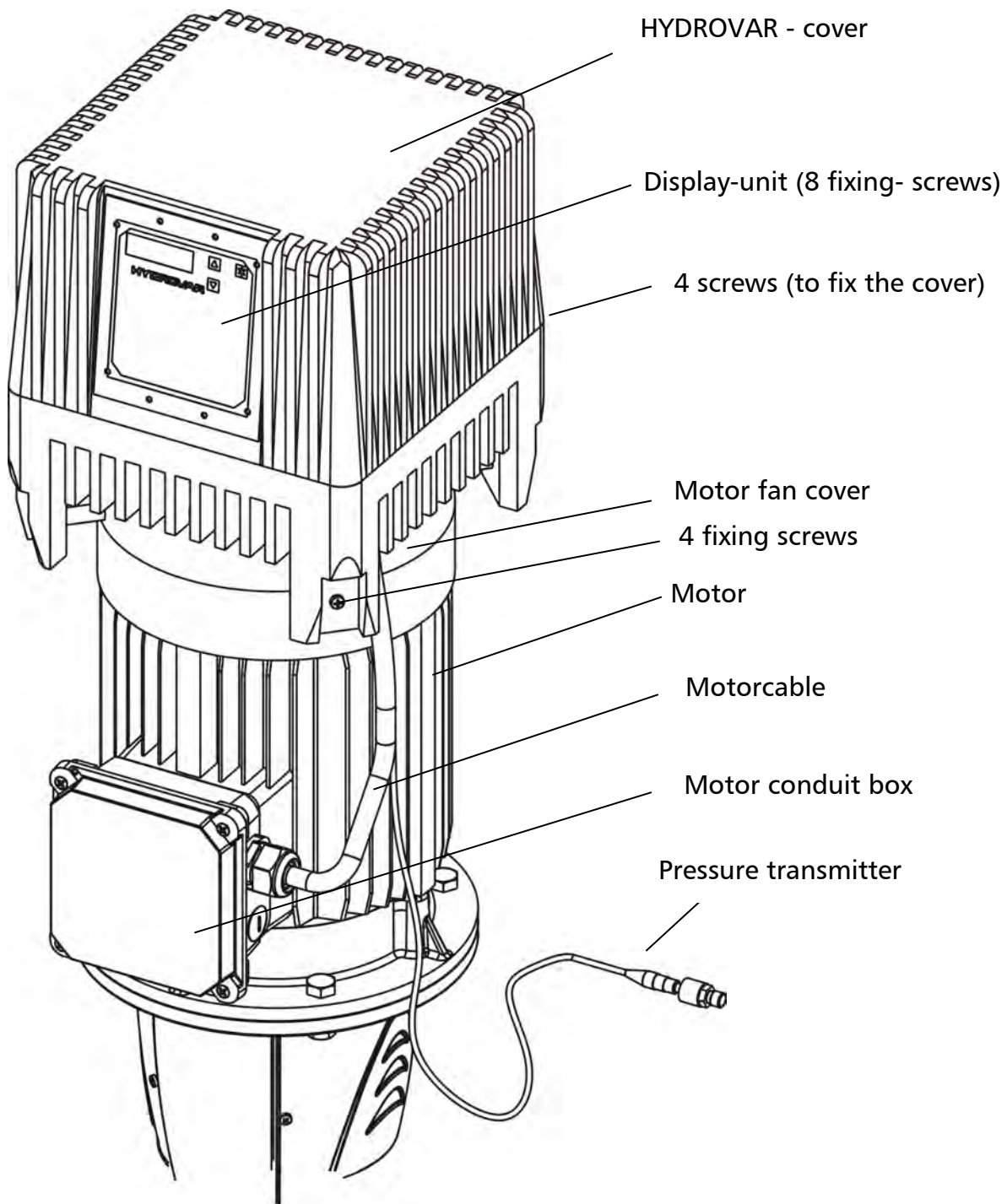

-
- Position the HYDROVAR at the motor, try to centre it as good as possible and prepare the boreholes for the fixing screws.

- Ensure that the position of the display is correct
If it is necessary, Display is changeable by 180°

Working process to turn the control-board:

- to turn the control-board you have to disconnect the connection to the power-board
- open the 4 hexagonal bolts (use a 7mm socket wrench) and turn the control-board
- mount the control-board and connect the 40 pin-plug to the power-board

- remove the motor-fan-cover if you have to install the HYDROVAR horizontal

- Mount the HYDROVAR by using the suitable fixing screws (M8), distance bushes and screw-nuts (this should be self-locking) at the motor-fan-cover

- If the HYDROVAR is mounted horizontal, a additional bracing may be required

6 Electrical installation and wiring



All installations and maintenance have to be performed by properly trained and qualified personal with proper tools!!



In case of a failure, disconnect or switch off electrical power and wait 5 minutes for capacitor discharge before servicing the HYDROVAR. Otherwise it can cause shock, burns or death.

6.1 Means of protection

Ask your power supply company which means of protection are required.

- Applicable:
- protective earthing
 - AC and DC residual current operated protective devices (RCD)
 - TN systems

Protective earthing:

- Please note that there can be a current to earth due to the capacitors in the input filter.
- A suitable protection unit has to be selected (according local regulations).

Residual current device (RCD):

- When using an RCD, make sure that it also releases in the event of a short circuit inside the DC-part of the HYDROVAR to earth!
 - single phase HYDROVAR => use pulse sensitive RCDs
 - three phase HYDROVAR => use AC/DC sensitive RCDs
- The RCD has to be installed according local regulations!

Automatic circuit breaker:

- Use automatic circuit breaker with C-type characteristic curve
- Rating of the line-protection (see chapter 3. Technical Data)

Internal protective devices of the HYDROVAR:

- The malfunctions short circuit, under- and over-voltage and the overheating of the electronic components (overload) are controlled by the HYDROVAR.

External protective devices:

- Additional protective functions like motor overheat and low water protection, are controlled by external equipment.

6.2 EMC-electromagnetic compatibility

To ensure the electromagnetic compatibility the following points must be observed for cable installation:

Earth / ground to ensure EMC

- **Protection earth**
It is important to connect the HYDROVAR to PE, because of the earth leakage current.
- **HF earth connection**
Ground cables should be as short as possible and with lowest impedance.

Signal cables

Control and signal cables should be screened types to prevent disturbances from outside. The screen should be only connected to ground on one side; otherwise it is possible that the screen has a ground current. The screen should be connected with cable-clips extensive to HYDROVAR GND.

Signal cables should be installed separate from motor- and power- supply cables
If signal cables are installed in parallel to motor-cables or to power supply cables for a longer distance, the distance between these cables should be more than 200mm.
Don't cross power cables with control cables-if this is not possible, cross them only 90°

Motor cables

To prevent EMC and capacitive currents, we advise to install the HYDROVAR directly at the motor. If the HYDROVAR is mounted separately, keep the motor cable as short as possible. We recommend using a screened cable or one protected by a metal sheath.

- It is necessary to connect both ends of the screen to ground, but these **connections couldn't replace the potential equalization.**
- We suggest a cable-clip for an optimal connection of the screen.
- Pigtails should be prevented, because they raise the impedance of the screen and affect the shielding effect at a high frequency.
- The power cable and the motor cable should be installed as distant as possible.

For motor cable lengths from 20 to 100 meters it is necessary to install an output filter between the HYDROVAR and the motor as shown in the diagram below.
The filter has to be mounted as close as possible to the HYDROVAR (max. distance 2 meters).

For further information contact our sales or service department.

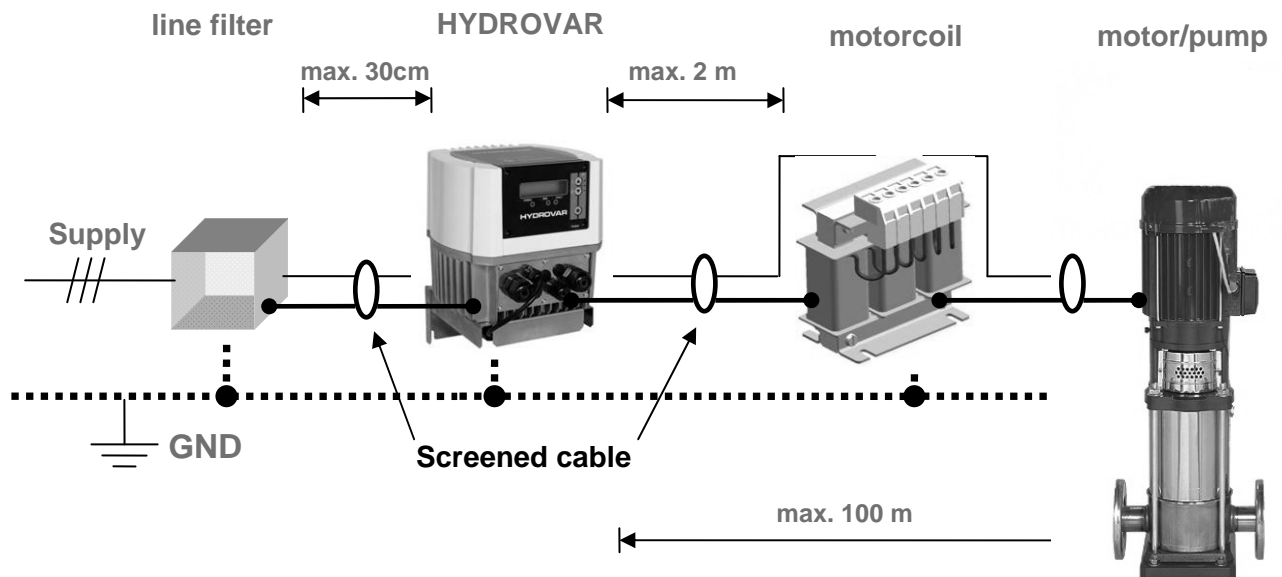

Additional component line choke (coil)

Line coils are available as an option and should be mounted between the HYDROVAR and the main fuse. The Line coil should be as near as possible at the HYDROVAR (max. 30 cm distance)

Advantages:

- better efficiency
- reduction of current harmonics

Applications:

- high short circuit currents
- compensation-plants without a coil
- asynchronous motors who are responsible for a voltage drop >20% of the line voltage

EMC summary

- Install potential equalization according local regulations
- Don't install the motor-cable in parallel to the signal-cable or the power cable
- Use screened motor- and signal-cables
- Connect both ends of the screen of the motor-cable to the ground
- Connect only one end of the screen of a signal-cable to the ground
- Motor-cable as short as possible
- Use a motor-coil if the cable is longer than 20 meters (max. 100 meters motor-cable)
- Pigtails should be prevented

6.3 Wiring and connections

Remove the screws holding the top cover of the HYDROVAR.
(Caution: At HV3.15e - 3.22e also the 8 screws of the display have to be removed!)
Lift off the top cover and you could see the following parts.

HV 2.1f – 3.11f

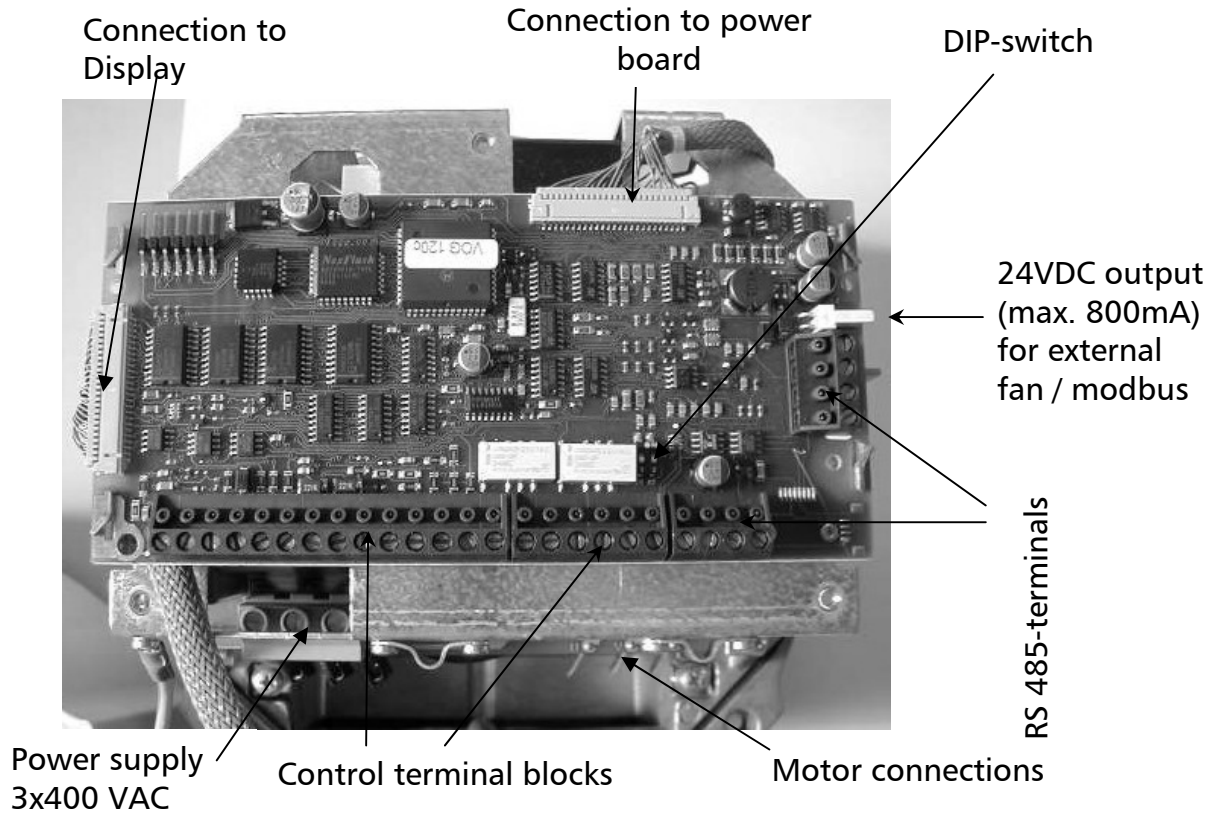

HV3.15e – HV3.45e

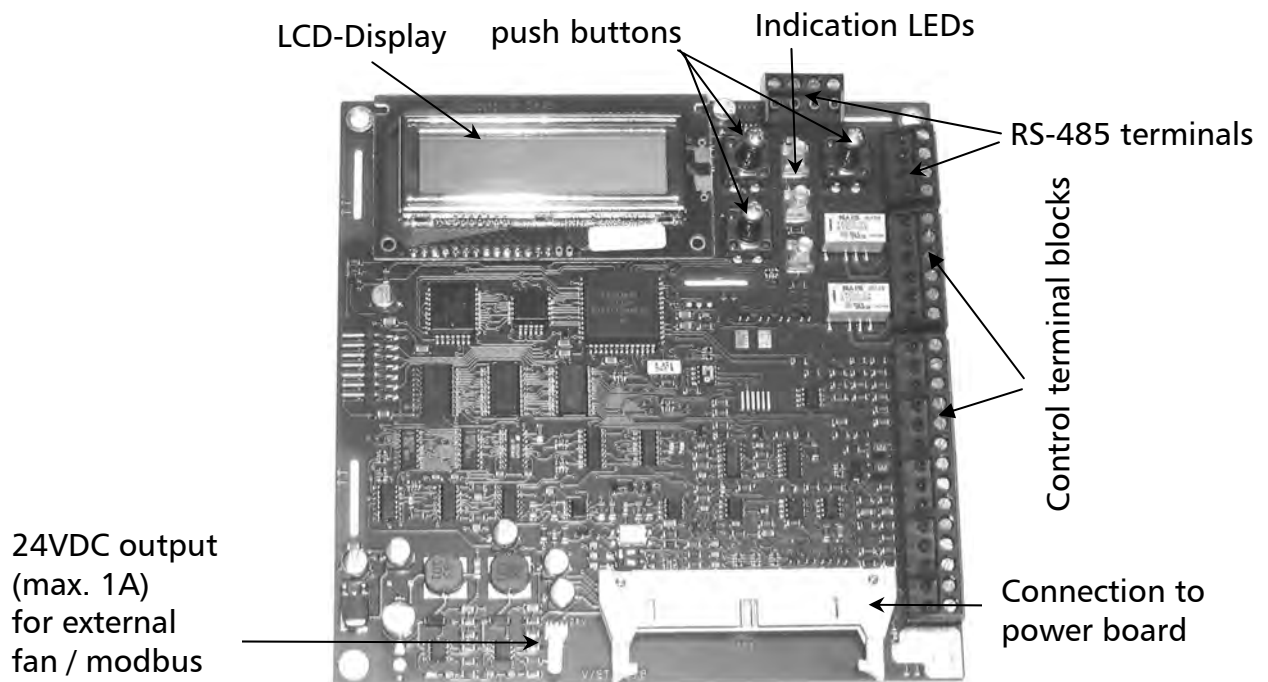

6.3.1 Main Voltage Terminals

The power supply is connected to the power section:

- terminal L1 + N (1 x 230 VAC, single-phase)
- terminal L1 + L2 + L3 (3 x 400 VAC, three-phase)

HV 2.1f / 2.2f

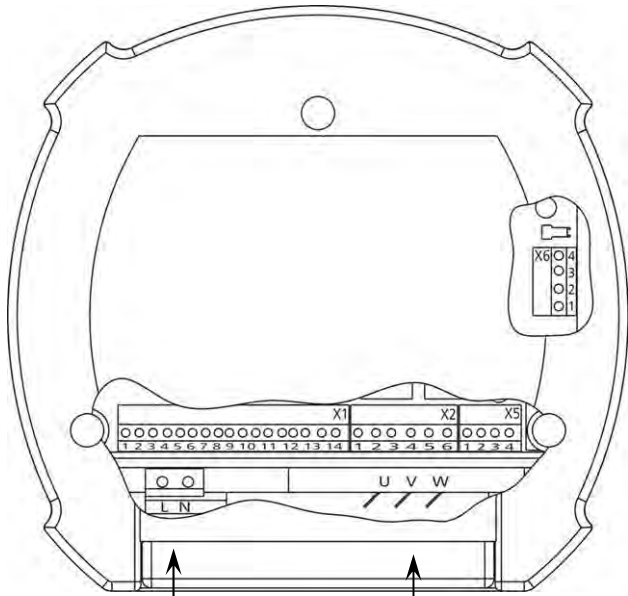

Power Supply
1x230 VAC

Motor connection

HV3.2f - 3.11f

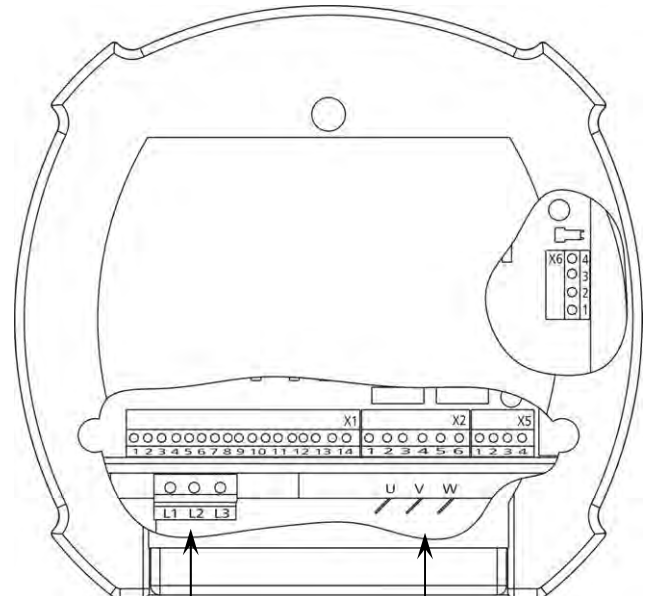

Power Supply
3x400 VAC

Motor connection

HV 3.15e – 3.22e

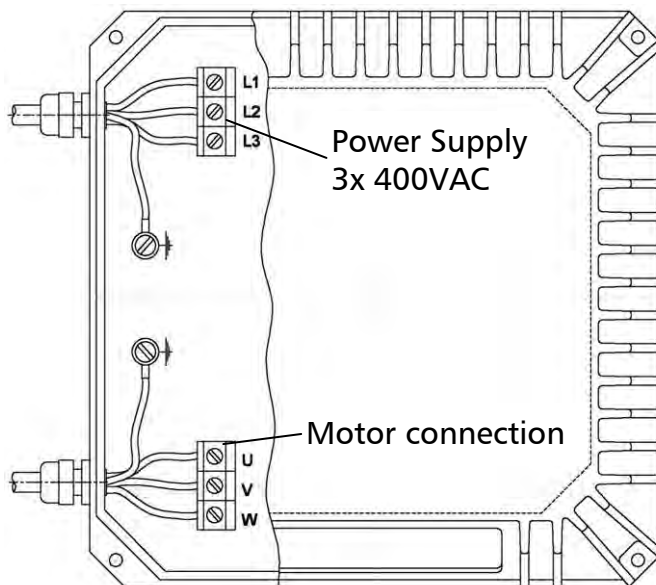

Power Supply
3x 400VAC

Motor connection

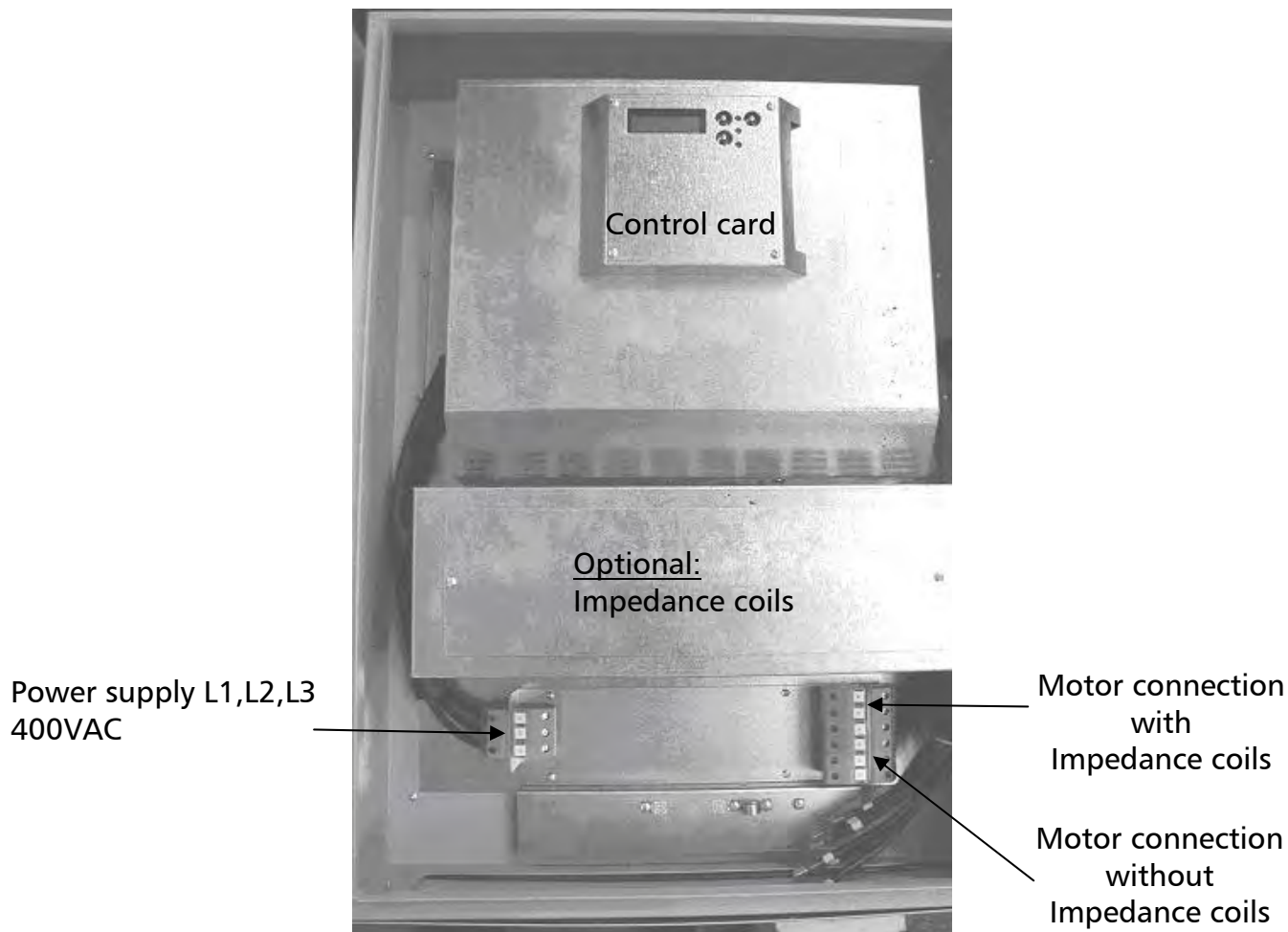

Mounting the distance bolts to enable the HYDROVAR operating with closed panel door. This should be done before mounting the unit on the wall:

- 1) Affix the adhesive label on the outside of the panel door
- 2) Open the door and mount the adhesive label for the display and the control buttons
- 3) Justify the distance bolts (three pieces are included) on the control buttons you want to control from outside when the panel door is closed
- 4) Close the door of the switchboard and press the control buttons to affix the distance on the outside adhesive label.

Cable entry:

On the bottom side of the HYDROVAR there are holes for 2xM40 screwed cable gland for motor and power supply cable and 3xM12 and 2xM16 screwed cable gland for control cables.

Cooling:

Both fans inside the HYDROVAR start when the motor is running. The fans on the backside of the cooling body are controlled with an NTC and start when the temperature of the power module reaches 50°C.

6.3.2 Motor connection

Mounting of the PTC

Variant A :

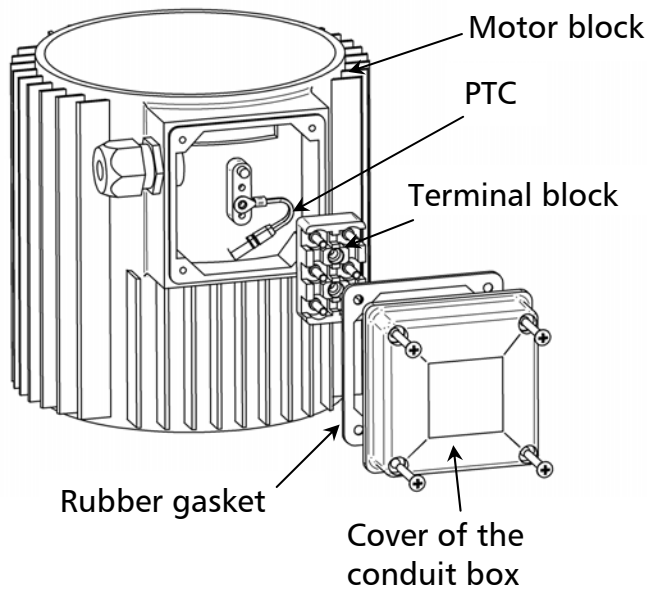

Variant B :

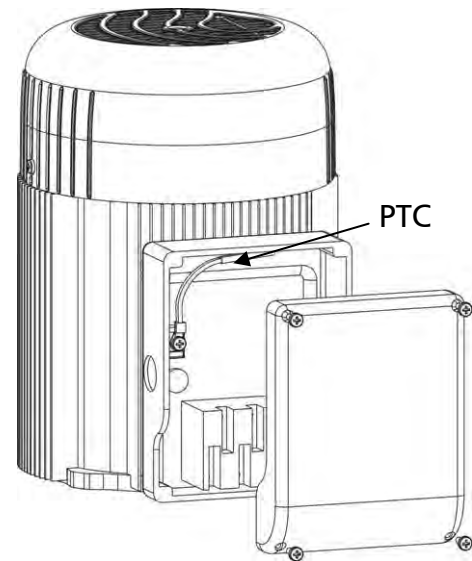

1. Open the cover of the conduit box and remove also the terminal block inside
2. Fix the PTC (Variant A or B)
3. Remounting of the terminal block
4. Electrical connection of the motor cables

The PTC should be fixed to the metal compound of the motor. This is necessary to measure the right temperature of the motor!

The connection of the motor cable depends on the type of the motor and can be done in star- or delta connection.

The right connection for the motor has to be selected as shown on the motor label according to the output voltage of the HYDROVAR.

star - connection

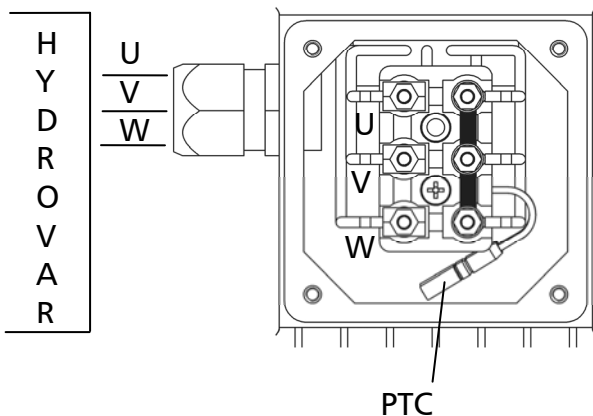

delta - connection

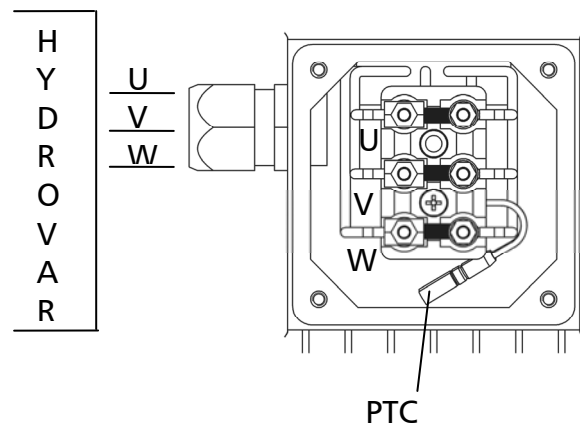

6.3.3 Control Terminals

All control cables which are connected to the control- or RS485-terminal have to be screened.

If unscreened control cables are used, signal interference may occur and could interfere to the function and signals of the HYDROVAR.

Don't connect the ground of the control card to different voltage potentials.

All electronic ground terminals and GND of the RS 485-interface are connected internally.

Terminals:	X1/	1	GND , electronic ground
		2	Actual value input 4-20mA, [Ri= 50 Ohm]
		3	Power supply for external sensor [15VDC, max. 100mA]
		4	GND , electronic ground
		5	External on/off (release) [5VDC, Ri=10kOhm] contacts suitable for switching <10VDC are necessary
		6	GND , electronic ground
		7	Low water [5VDC, Ri=10kOhm] (e.g. incoming pressure switch or water level switch)
		8	Thermal switch or PTC (mounted in the motor terminal box) [5VDC, Ri=10kOhm]
		9	Thermal switch or PTC
		10	GND , electronic ground
		11	Analogue output 0-10 VDC, [max. 2mA] to show actual value or actual frequency
		12	Current signal input 4-20mA to determine the required value or the offset
		13	Voltage signal input 0-10VDC or 2-10VDC to determine the required value or the offset
		14	Digital input for 2 nd Required value

Terminal: (dry contacts)	X2/	1	Fault signal relay	NC	} [Max. 250VAC] [0,3A resistive load] [Max. 220VDC] [0,3A resistive load] [Max. 30VDC] [2A resistive load]
		2		CC	
		3		NO	
		4	Pump running relay	NC	
		5		CC	
		6		NO	

NOTICE! In case of no error, the fault relay (X2/2 - X2/3) is closed!

Terminal:	X5 and X6/	1	RS 485 SIO -	LOW
		2	RS 485 SIO +	HIGH
		3	RS 485 GND	
		4	RS 485 + 5 VDC	[max. 20mA] supply of external interface converter

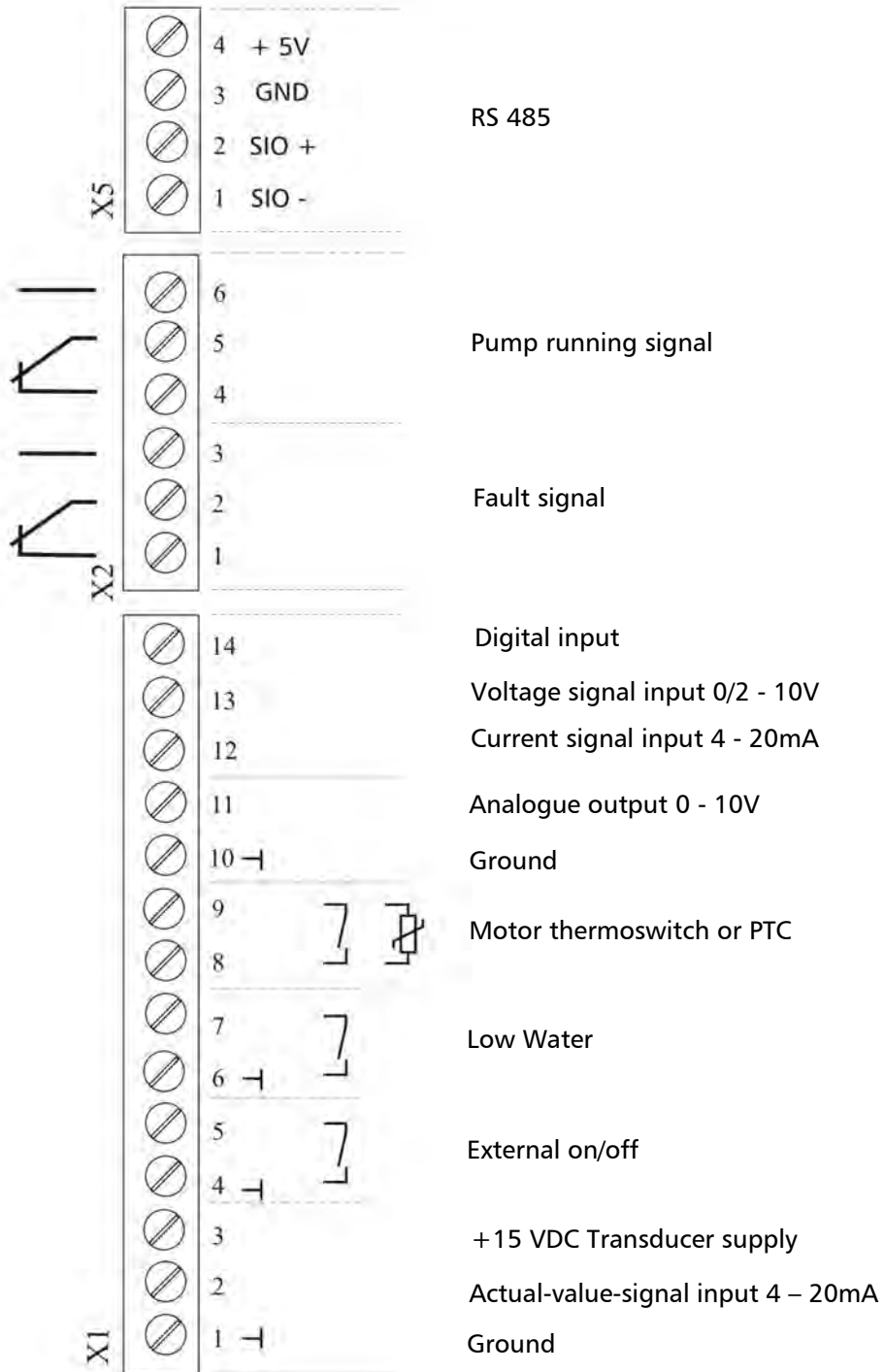
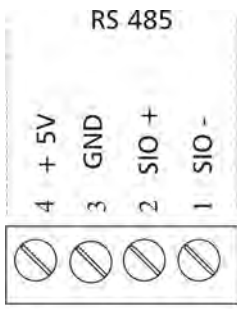

6.3.3.1 Connection examples

Terminal X1

- **Transducer – Actual-value- signal input**

- Connection of a 2-wire transducer (e.g. standard pressure transducer PA22)

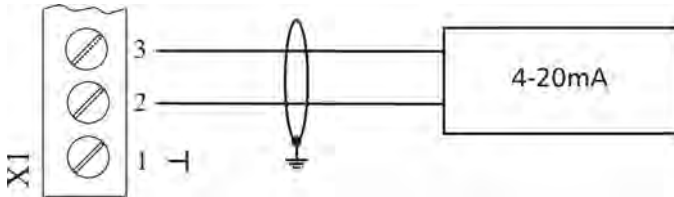

- Connection of an active actual-value-signal

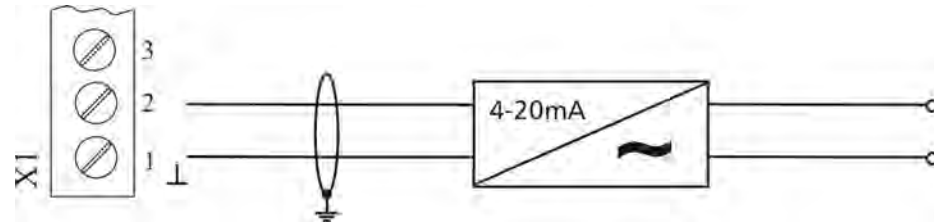

- **Actual value – Frequency indicator** (how to program see chapter 9.26)

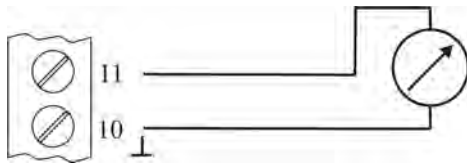

e.g.: to display the actual motor frequency

- **2nd Required value** (how to program see chapter 9.19)

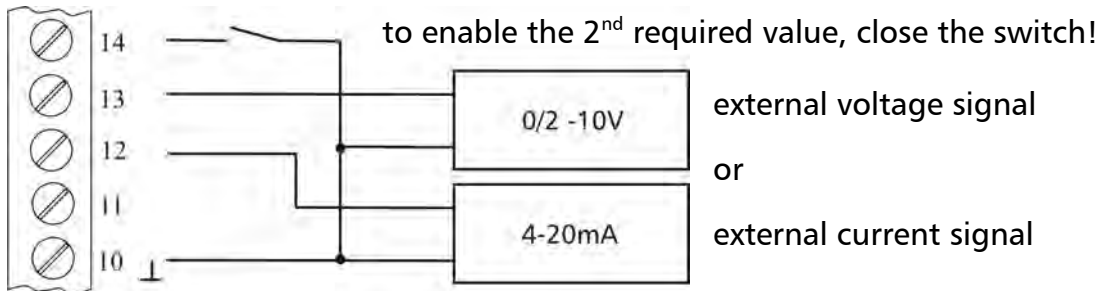

- **Offset** (how to program see chapter 9.21)

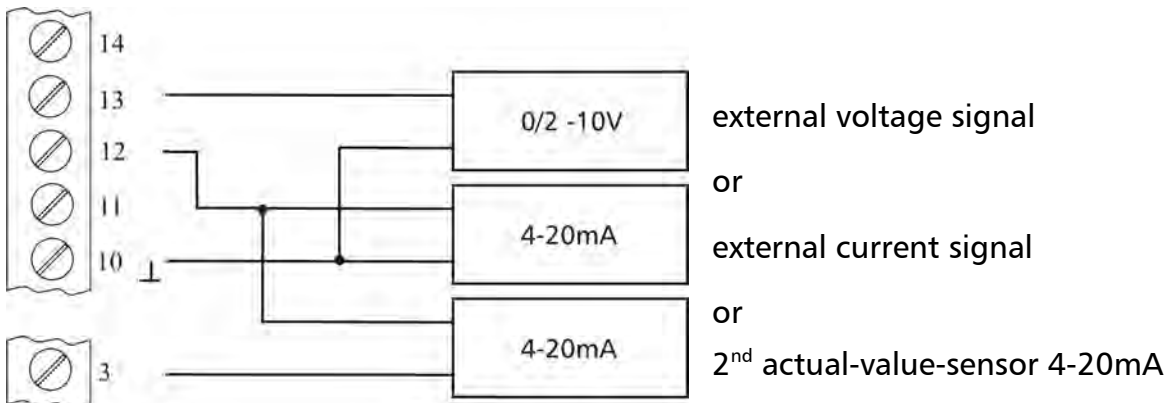

Terminal X2

- **Pump running signal** (how to program see chapter 9.20)

Ext. 250VAC / 220VDC

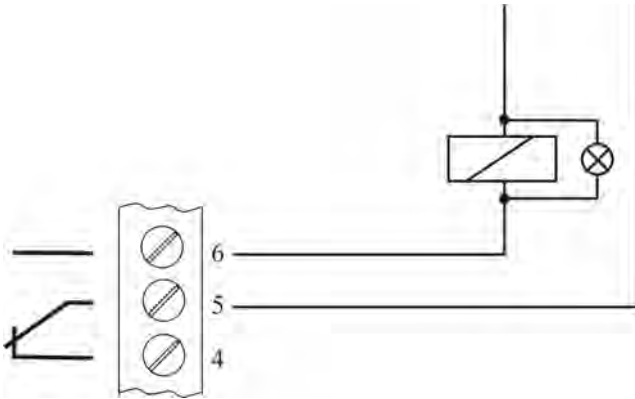

X2/ 5 and 6 closed:

- ➔ motor run indication
- ➔ or start/stop of a fixed speed pump

- **Fault signal**

Ext. 250VAC / 220VDC

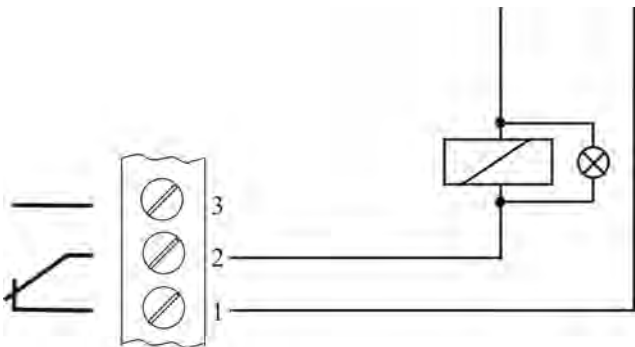

X2/ 1 and 2 closed:

- ➔ if there is an Fault / Error or power supply of the HYDROVAR is cut of

Terminal X5 / X6

For multi-pump applications (synch. or multicontroller) you have to connect each HYDROVAR (max. 4) via the RS 485 interface. (Use screened cables!)

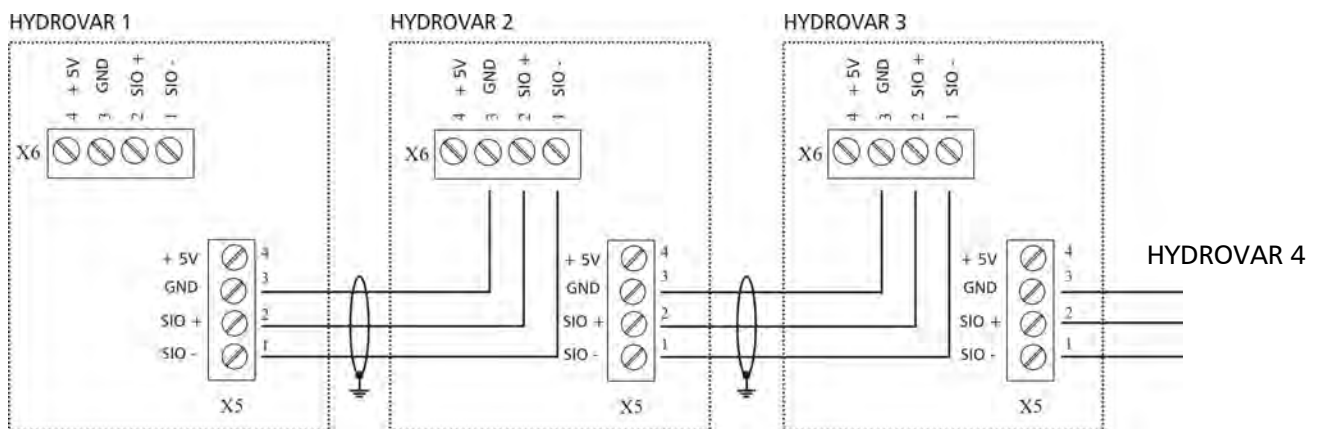

Using the optional Modbus interface, one or more HYDROVAR could communicate via the standardized Modbus-protocol with an external-control-device (e.g. PLC).

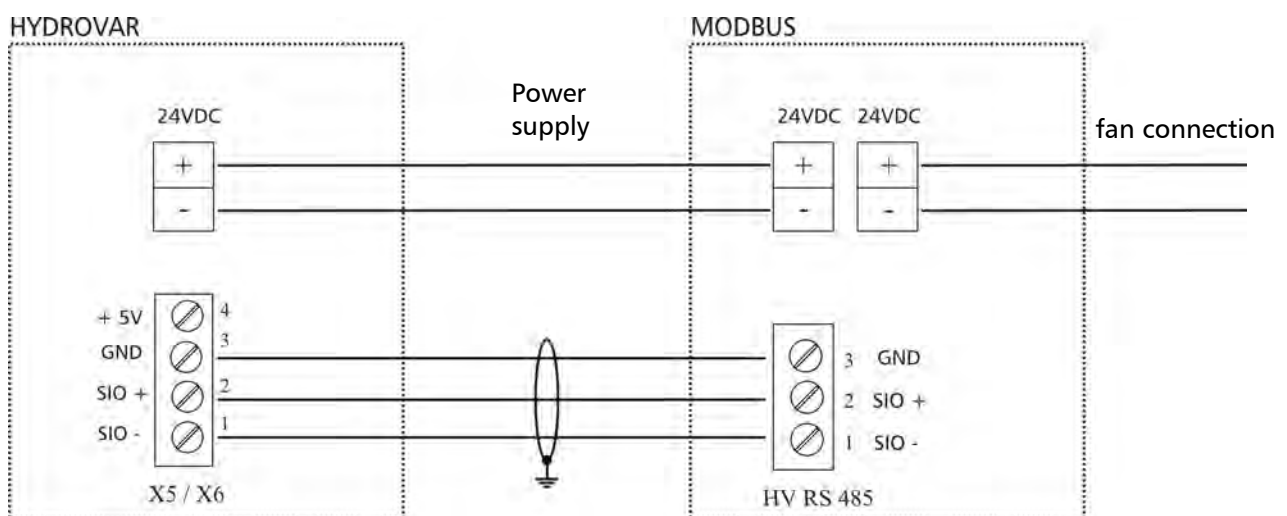

The terminal "HV RS485" is the RS485 interface to the HYDROVAR.

SIO-, SIO+ and GND must be connected with the corresponding terminals of the RS 485 interface of the HYDROVAR.

Caution! GND must be connected because it is the ground connection for the whole interface.

For the power supply of the interface you have to connect the terminal of the fan on the Modbus - interface and the HYDROVAR. (see chapter 6.3)

The second terminal on the Modbus could be used to connect a fan.

6.4 Selection of the switching-frequency



Before changing the switching frequency, disconnect the power supply, otherwise the HYDROVAR power module could be destroyed.

A switching-frequency of 8kHz only should be selected if the HYDROVAR is mounted directly on the motor in order to reduce the noise level.

In case of longer motor cables the switching-frequency should be decreased to reduce losses in the cable as well as the temperature in the motor.

For applications with submersible pumps select 2,5kHz switching-frequency.

SW		switching-
1	2	
OFF	OFF	8kHz (standard)
ON	OFF	5kHz
OFF	ON	4kHz
ON	ON	2.5kHz

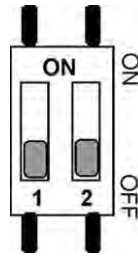

HV 2.1f - 3.11f

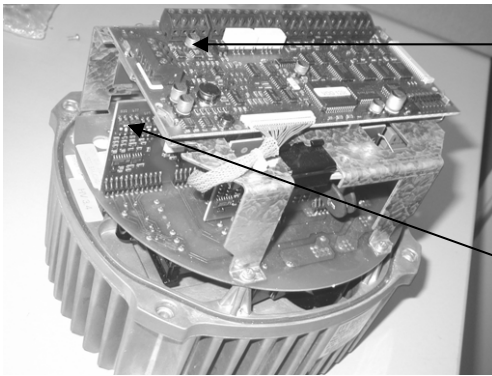

DIP-Switch to select the switching frequency

SW 30/SW 31
DIP-Switches to decrease the max. output current

HV 3.15e - 3.45e

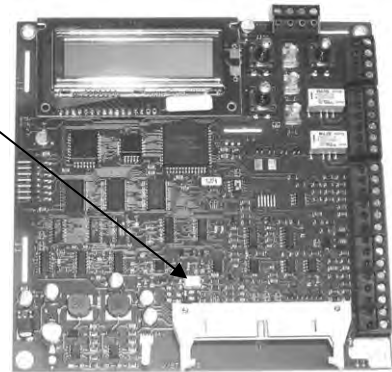

6.5 Reduction of the maximum output current

When a motor with lower nominal power is used, the max. output current should be adjusted accordingly. Only possible for HV 2.1 f - 3.11 f

HV Type	Output current [A]			
	100%	85%	65%	50%
2.1	7.00	5.95	4.55	3.50
2.2	10.00	8.50	6.50	5.00
3.2	5.70	4.85	3.71	2.85
3.3	7.00	5.95	4.55	3.50
3.4	9.00	7.65	5.85	4.50
3.5	13.50	11.48	8.78	6.75
3.7	17.00	14.45	11.05	8.50
3.11	23.00	19.55	14.95	11.50

Possible setting	SW30 A	SW30 B	SW31 A	SW31 B
100%	ON	OFF	OFF	OFF
85%	OFF	ON	OFF	OFF
65%	OFF	OFF	ON	OFF
50%	OFF	OFF	OFF	ON

The reduction of the maximum output current also affects the Overload-detection!

6.6 RFI - switch

For the HYDROVAR types HV2.1 – HV3.22 there are installed new additional filter capacitors, which provides an improved filter characteristic in order to avoid RFI (Radio Frequency Interferences) when mounting the HYDROVAR on the wall and using longer cables between the HYDROVAR and the motor.

This filter element is switch able and is deactivated in the default setting (switch contact opened), because for standard mounting version (motor mounted and using standard motor cable length) the filter is not required.

The filter should be only activated in case of separate mounting (Wall mounted versions) of the HYDROVAR.

NOTE: Due to the additional filter capacity the earth leakage current will increase, if the filter is activated. Therefore in case of using ELCB-relays (earth-leakage circuit breakers, RCD), they must be suitable for VFDs (suitable for protecting equipment with a DC-content in the faulty current) as well as suitable for a high leakage current => 300mA.

HV 2.1f / 2.2f



HV 3.2f – 3.11f

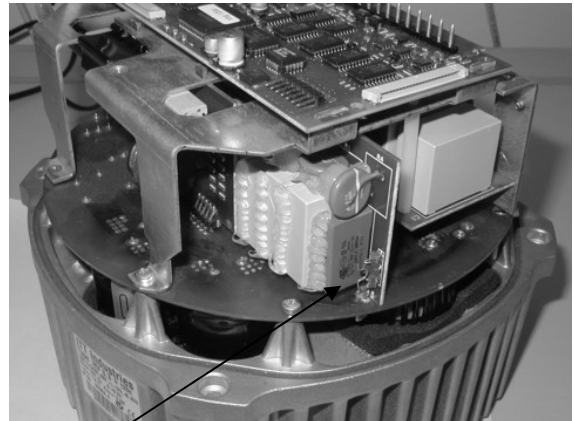

HV 3.15f – 3.22f

Switch contact

Opened: RFI filter function deactivated (default setting)

Closed: RFI filter function activated (for wall mounted version)



WARNING: The switch may not be operated in case the HYDROVAR is still connected to the mains supply. Before changing the position of the switch (ON/OFF) you have to be sure that the HYDROVAR is disconnected from the mains supply.

7 Programming

7.1 Display – control panel

HV 2.1f – 3.11f

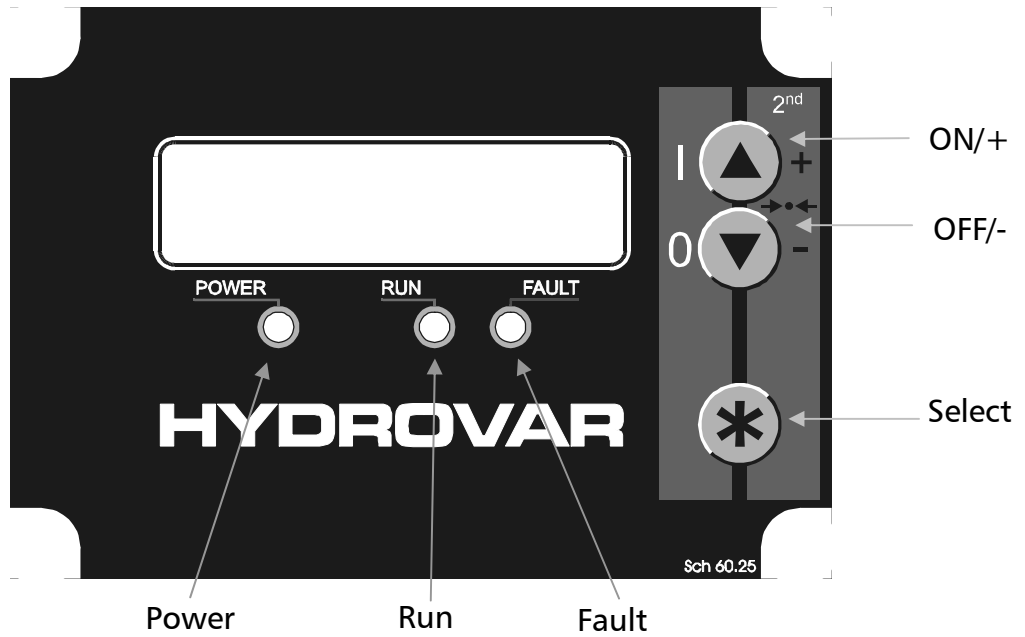

HV 3.15e – 3.22e

HV 3.30e – 3.45e - inside

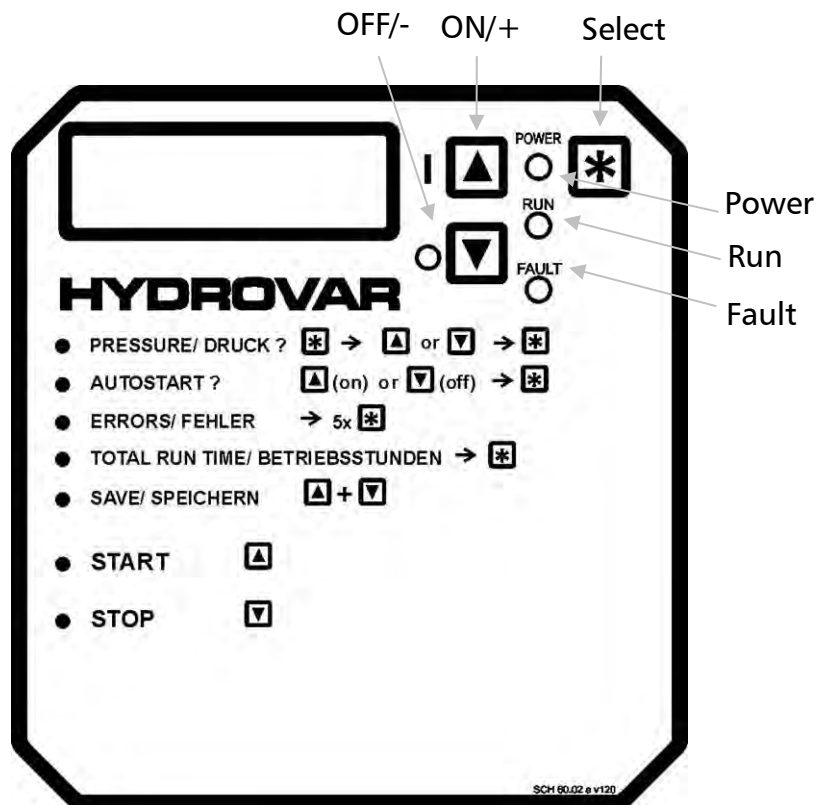

7.2 Function of the push buttons

- ↑ Start of the HYDROVAR or increase the value in the menu
- ↓ Stop of the HYDROVAR or decrease the value in the menu
- * Short pressing: Change to next parameter in the menu
- * + ↓ Change to previous parameter in the menu
- * Long pressing: Enter the submenu or change back to the main menu
- ↑ + ↓ Saving of all settings
- * + ↑ Long pressing: The auxiliary texts of the actual parameter is shown or language selection in the first window
- ↓ + short ↑ Change to faster scrolling down of the value
- ↑ + short ↓ Change to faster scrolling up of the value
- * + ↓ + ↑ RESET of a failure by pressing all three buttons simultaneously for about 5 seconds

7.3 Language Selection

The information on the display and all parameters can be called up in the following languages:

- German
- English
- Italian
- French
- Spanish
- Portuguese
- Dutch

To select the desired language proceed as follows:

- Shortly press * + ↑ simultaneously (in 1st display)
⇒ The actual language will now appear in the second line
- The desired language can be selected with the button ↑ or ↓.
- After the language has been selected, shortly press the * button and the display will change back to the first window of the main menu.
- The selection of the language will be saved automatically

8 Parameters of the main menu

After connecting the HYDROVAR to the power supply the following index will be shown:

SW-Ver:	VOG 120
Date:	xxxx

The current software version with the date of programming is displayed for about 3 seconds

If the connection of terminal X1/4-X1/5 (external release contact) is open, the following message appears:

INVERTER LOCKED enable inverter

To start the HYDROVAR, bridge these two terminals or close the external ON/OFF switch.
If any other error occurs, see chapter 10. Error messages!

The following two windows (1st Window and Required value) depend on the selected mode: (see chapter 9.16)

a) Active MODE = Controller: (Default setting)

1.

ITT INDUSTRIES XX.X BAR

 1st display at Mode Controller

Press the * button to change to the next parameter

2.

REQUIRED VALUE 1 X.XX BAR

 Set the desired required pressure with either ↑ or ↓ and then shortly press the *- button.
(Default setting 3,5 bar)

If you want to change to the 2nd Required Value you have to close the external contact at terminals X1/10-X1/14.

After closing this contact, the display changes from REQUIRED VALUE 1 to

- 2.1

REQUIRED VALUE 2 ADC-X XX.X BAR

 In this window the configuration of the 2nd required value is shown. (see chapter 9.19)

ADC-X or INT: shows the source of the external or internal Required Value 2.
XX.X Bar: shows the actual value of the Required Value 2.

Press the * button to change to the next parameter (**menu 3**)

b) Active MODE = Actuator:

1.

ITT INDUSTRIES Frequency XX.X Hz

 1st display at Mode Actuator

- In this mode an external controller is used, so the HYDROVAR will not control the set value but will only be responsible for running the connected motor at a frequency proportional to the value of the analogue input signal originating from the external source.
- In the "Actuator" mode, the output frequency is proportional to the input signal on terminal X1/2 ⇒ 4-20 mA = 0 - max. frequency
- The frequency varies with fast RAMPS 1 and 2.
- The functions "Lack of water", "Motor overheat", "external ON/OFF" and all other internal protections still work.

Press the * button to change to the next parameter (menu 3)

c) Active MODE = Synch. Controller or Multi-controller:

1.

ADR X (x) P X XX.X Bar

 1st display at the Synch. Controller or Multicontroller mode.

ADR X Pump address (see chapter 9.23.1)

(x) Indicates the source of the required value. It is always shown at the current HYDROVAR which delivers the active required value.
(To select the source, see chapter 9.22.5)

(x)=(1) ⇒ required value 1 of the active HYDROVAR

(x)=(2) ⇒ required value 2 of the active HYDROVAR

P X Indicates the current pump positioning within the system, where as P1 = Master pump, P2 = 1st lag pump, and so on...

Press the * button to change to the next parameter

2.

REQUIRED VALUE 1 X.XX BAR

 Set the desired set pressure with either ↑ or ↓ and then shortly press the *-button.

If several HYDROVARs are connected via the RS-485 interface, one unit must be ready for operation when the set pressure is changed, otherwise the set value will not be accepted by the follow-up pumps. Afterwards the new required pressure has to be saved (see parameter SAVE) in all pumps.

If you want to change to the 2nd Required Value you have to close the external contact connected to X1/10-X1/14.

After closing this contact, the display changes from REQUIRED VALUE 1 to

2.1

REQUIRED VALUE 2 ADC-X XX.X BAR

 This window shows the condition of the second required value. (see chapter 9.19)

ADC-X or INT: shows the source of the external or internal Required Value 2.

XX.X Bar: shows the actual value of the Required Value 2.

Press the * button to change to the next parameter (menu 3)

d) Active MODE = Manual Control:

1.

ITT INDUSTRIES Frequency XX.X Hz

 1st display at Mode Manual Control local.

Continue by pressing the * -button

2.

MANUAL CONTROL X.X Hz X.XX BAR

 Set the desired set pressure with either ↑ or ↓ and then shortly press the * -button.

Press the * button to change to the next parameter (menu 3)

The following parameters of the main menu are valid for all selected Modes!

3.

AUTO - START ON

 Select (ON) with ↑ or (OFF) with the ↓ button.

If AUTO-START = ON, the HYDROVAR starts automatically after a remedy of a failure or disconnection of the power supply.

If AUTO-START = OFF, the HYDROVAR won't start automatically after a remedy of a failure or disconnection of the power supply.

After remedy of the failure or reconnection of the power supply the following message is shown:

- 3.1

NO AUTOSTART disable inverter

 To restart the HYDROVAR, press ↓ to quit and ↑ to restart.

Press the * button to change to the next parameter

Error memory

All errors are only readable in English.

4.

E R R O R 1

 Latest error, happened on the HYDROVAR

Press the * button to change to the next parameter

5.

E R R O R 2

 Error, happened before the latest error

Press the * button to change to the next parameter

6.

E R R O R 3

 Error, happened before error 2

Press the * button to change to the next parameter

7.

E R R O R 4

 Error, happened before error 3

Press the * button to change to the next parameter

8.

E R R O R 5

 Error, happened before error 4

More information about errors, see chapter 10.

No Error ... is shown if the error memory is empty and no failure happened!

Press the * button to change to the next parameter

9.

TOTAL RUN TIME 0000:00

 Runtime of the motor / HYDROVAR. This parameter shows how long the motor was powered by the HYDROVAR

Press the * button to change to the next parameter

10.

SAVE ??? ↑ + ↓

 Simultaneously press buttons ↑ and ↓ until...

11.

SAVE ??? SAVED

 appears on the display. After five seconds the display changes back to the 1st display

NOTICE! All changes has to be saved, otherwise they would be lost in case of a disconnection of the power supply!

9 Parameters of the Secondary Menu



Before entering the secondary menu these instructions must be read carefully to prevent incorrect settings which will cause malfunction.

All parameters can also be set during operation. Therefore you should be trained how to use the secondary menu.

We suggest stopping the HYDROVAR by pressing ↓ OFF during the first start-up.

INVERTER STOP
ON -> START

Press * for 3 seconds to change to

PASSWORD
0000

Set Password (0066 = Default) by pressing ↑ or ↓

NOTICE: The password must be entered at each entry into the submenu

PASSWORD
0066

Confirm by pressing * and the first window of the sub menu is shown

J O G – MODE
0.0Hz X.XX Bar

In the following chapters all available parameters of the secondary menu are listed (on the index window there is shown the European default setting).

9.1 JOG-MODE

J O G – MODE
0.0Hz X.XX Bar

Both Actual output frequency and actual value are shown.

- By pressing ↑ or ↓ in this menu, the internal controller of the HYDROVAR will be shut off and the inverter changes to manual mode.
- With the buttons ↑ and ↓ you can set any constant speed, with no influence of the actual value of the control signal!
- If this value becomes 0 Hz the HYDROVAR stop.
- If you set a frequency above 0.0 Hz, the HYDROVAR will start operating normally again in automatic mode as soon as you change window.

Press the * button to change to the next parameter

The parameters Window and Ramp Hysteresis and the Ramp settings as well are responsible for the control characteristic of the HYDROVAR and also guarantee the stop of the pumps at 0 demand in boosters and water supply stations.

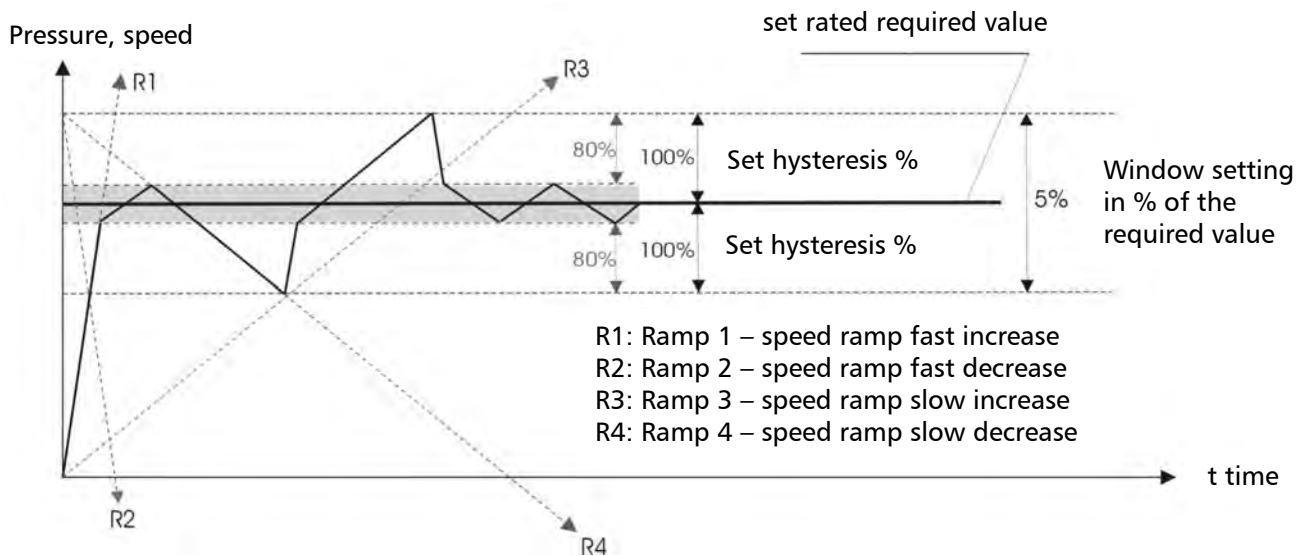

9.2 Window

<p>WINDOW 5%</p>

- Determines the band, where the slow Ramp changes to the fast Ramp
- Possible setting: between 0% - 100% of required value
 - for steep pump-curves and closed loop systems ~20-30%

Press the * button to change to the next parameter

9.3 Ramp Hysteresis

<p>RAMP HYSTERESIS 80%</p>

- Determines the band, where the fast Ramp changes to the slow Ramp or rather the change between the slow Ramps
- Possible setting: between 0% - 100%
 - for an accurate controlling (without automatic shut-off) ~99%

Press the * button to change to the next parameter

Ramp settings:

- Time setting of the Ramps will influence the control of the pump and shouldn't be changed at standard operation.
- Possible setting of each Ramp 0,05 - 1000 sec.
- The fast Ramps 1 and 2 are determined by the type (power) of the HYDROVAR.
(Default = 4 sec.; depending on the power of the HYDROVAR you should increase the time up to 15s)
- The Ramps 3 and 4 determine the speed of the internal HYDROVAR controller and depend on the system, that has to be controlled. (Default = 70 sec.)

To adjust the Ramps, press ↑ or ↓

9.4 Ramp 1: Fast acceleration time

RAMP 1 4.0 Sec

- Excessively fast running up time may cause an error (OVERLOAD) during the HYDROVAR is starting.
- Excessively slow running up time may cause a drop of the outgoing pressure during operation.

Press the * button to change to the next parameter

9.5 Ramp 2: Fast deceleration time

RAMP 2 4.0 Sec

- Excessively fast running down time tends to cause an error (OVERVOLTAGE)
- Excessively slow running down time tends to generate over pressure.

Press the * button to change to the next parameter

9.6 Ramp 3: Slow acceleration time

RAMP 3 70 Sec

- A too fast running up time may lead to oscillation and/or an error (OVERLOAD).
- A too slow running up time can cause a drop of the outgoing pressure during variation of the demand.

Press the * button to change to the next parameter

9.7 Ramp 4: Slow deceleration time

RAMP 4 70 Sec

- A too fast running down time leads to oscillation of the HYDROVAR and thereby of the pump.
- A too slow running down time can cause pressure fluctuations during variation of the demand.

Press the * button to change to the next parameter

9.8 Maximum Frequency

This parameter determines the maximum speed of the pump and at which output frequency the HYDROVAR has its max. output voltage.

The standard setting is according to the nominal frequency of the connected motor.

MAX. FREQUENCY 50.0 Hz

Possible setting between 40 and 70 Hz

Attention: Settings higher than 50 Hz may overload the motor!
Settings of 10% above nominal frequency cause a 33% higher power consumption!

Press the * button to change to the next parameter

9.9 Minimum Frequency

MIN. FREQUENCY 0.0 Hz

Possible setting between 0Hz and Max. frequency

At operation below the right min. frequency the HYDROVAR works with the fast Ramps.

Attention: The min. frequency depends on the selected pump type.
Especially for borehole applications the min. frequency must be set to ~30Hz.

Press the * button to change to the next parameter

9.10 Operation at minimum frequency

CONFIG FMIN f => fmin

Possible setting: f->0 or f-> f_{min}

f->0: After reaching the required pressure the frequency will go down to the selected MINIMUM FREQUENCY and the HYDROVAR will keep running for the selected "STOP DELAY" time (see next parameter). After this time the HYDROVAR will stop automatically.

f-> f_{min} : With these setting the pump will never stop automatically. Only the frequency will go down to the selected MINIMUM FREQUENCY. To stop the pump you have to open the external ON/OFF (terminals X1/4 and 5) or press the ↓ button.

Applications: circulation systems

The setting f->fmin can overheat the pump, when there is no flow through the pump. => bypass line for circulation pumps!

Press the * button to change to the next parameter

9.11 Delay time to shut off below minimum frequency

STOP-DELAY FMIN 5 s

Possible setting between 0 and 100s

- After running the pump for this selected time at minimum frequency, the pump will stop, if parameter CONFIG. FMIN is set to f -> 0

NOTICE: Problems with shut off the pump at 0 demand (too small or no pressure tank) may be solved by exceeding the required value during this delay-time.

- If the limit of the parameter ENABLE SEQUENCE CONTROL is exceeded and the relay configuration is set to SIMPLE MULTICONTROLLER (see chapter 9.20), the pump running relay (X2/4-5-6) will be closed after running the pump for this selected time.

Press the * button to change to the next parameter

9.12 Boost

BOOST 5.0 %

Setting of the motor starting voltage in % of rated voltage (0 - 25% of maximum input voltage is possible)

This value determines the characteristics of the voltage/frequency curve.

In particular, it refers to the voltage increase during the motor starting stage as a percentage of the nominal voltage. Take care that settings are kept as low as possible so that the motor does not become thermally overloaded at lower frequencies.

If the boost is set too low, a failure (OVERLOAD) may occur because the starting-current is too high.

Press the * button to change to the next parameter

9.13 Sensor – Adjust

Zero point adjustment (4mA) of the transducer: Necessarily required for multi pump applications.

SENSOR ADJUST
↑ + ↓

Make sure that the system is not pressurized.
Press buttons ↑ + ↓ simultaneously until a new message appears ...

SENSOR ADJUST
Adjusted

This message confirms the calibration of the transmitter's zero point by associating the minimum value of the transmitter's output signal (4mA) for example to a pressure of zero bar.

SENSOR ADJUST
out of range

This message appears when the presence of residual pressure in the system does not enable the calibration of the zero point. Depressurize the system completely and change the adjustment.

Press the * button to change to the next parameter'

9.14 Sensor - Curve

SENSOR-CURVE
Linear

Internal calculation base of the actual value (4-20mA)

Possible Setting and its application:

- **linear:** Pressure control, differential pressure control, level, temperature and flow control (inductive or mechanical).
- **quadratic:** Flow control with an orifice plate together with a differential pressure transmitter.

Press the * button to change to the next parameter

9.15 Setting of the sensor range

Before changing the sensor range, you have to select the right dimension unit (see 9.27).

SENSOR RANGE
20mA = 10.0Bar

Determines the end value (=20mA) of the measuring transmitter (e.g. 10.0 bar pressure transmitter)
Adjustable range: 20mA = 100% of the sensor range

Following values corresponds to the possible adjustable ranges!

Bar: 0,2...100 bar	psi: 2,9...1450,5 psi	m3/h: 4...2400m ³ /h
g/min: 17...10560g/min	ft: max. 6-3345ft	mH2O: max. 1019,5mH2O
without unit: 2-1000	%: 0...100 %	

Press the * button to change to the next parameter

9.16 Operation Mode

MODE:
Controller

Select with the \uparrow and \downarrow buttons

Possible Settings:

Controller:

This mode should be selected if only one HYDROVAR pump is in operation and there is no connection to any other HYDROVAR via RS485 interface.

Multicontroller:

If more than one pump should operate together via the RS485 interface (follow-up pump control), this mode must be set.

Advantages: If the pumps are connected via RS485 interface there are the possibilities of automatic switch over because of pumps being out of order, cyclic change of lead and lag pumps or automatic start and stop of lag pumps following the actual demand.

Synchronous Controller:

The Synchronous Controller mode is working in the same way like the Multicontroller mode. The only difference is that all pumps in the multi pump system are running at the same frequency.

Advantages: In the synchronous mode the pumps are running with a better efficiency.

Actuator:

The Actuator application is only used if you have an external controller and the HYDROVAR is used like a standard frequency converter.

In the Actuator-Mode, the internal controller is shut off, and the output frequency is proportional to the input signal ($X1/2$) $\Rightarrow 4-20 \text{ mA} = 0 - f_{\text{max}}$.

The frequency changes with the programmed Ramps 1 and 2. The functions of low water, thermal protection and external ON/OFF are still working.

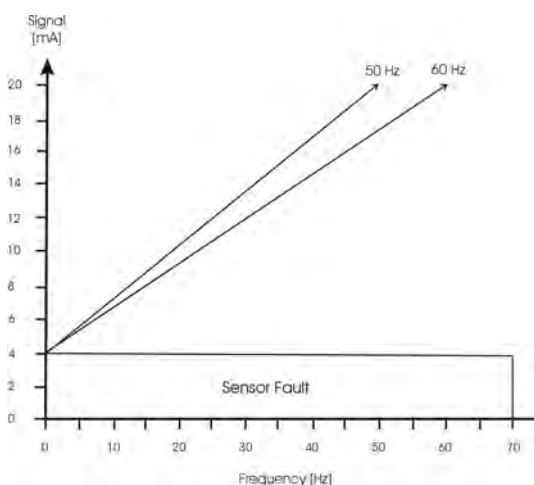

Manual Control:

If MANUAL CONTROL is selected, the parameter REQUIRED VALUE will change to MANUAL CONTROL in the main menu, where the actual frequency and the actual value are displayed (according to the JOG-MODE in the submenu).

- Now the frequency can be changed with the ↑ and ↓ buttons
- The speed of the pump will change along the fast Ramps
- After selecting the right frequency, it can be saved in the standard SAVE window
- After a supply failure, the pump will run with this selected frequency (depending on the parameter AUTO-START) automatically.
- In the 1st display, the actual frequency is shown.
- CONFIG. FMIN will not work in this mode.

Attention: Driving the pump in a not allowed speed range can damage the motor or the HYDROVAR!

Press the * button to change to the next parameter

9.17 Regulation mode

REGULATION MODE Normal

Normal: Speed is increased with falling actual value signals. (e.g.: Control at constant output pressure)

Inverse: Speed is reduced with falling actual value signal. (e.g.: Control at constant suction pressure or at constant level)

Press the * button to change to the next parameter

9.18 Start Value

START VALUE disabled

This parameter gives you the start value after pump stop in percentage of the required value.
Adjustable between disabled and sensor range.

e.g. required value: 5.0 bar
start value: 2.5 bar

If the pump system has reached the required pressure of 5.0 bar and there is no more consumption, the HYDROVAR shuts off the pump.

When the consumption grows up and the pressure goes down the pump will normally start. If you have selected a START VALUE of 2,5bar the pump will start after the pressure drops below.

Press the * button to change to the next parameter

9.19 2nd Required Value

CONFIG. REQ. VAL.2 OFF

With this parameter a 2nd independent required value can be selected and at the same time the source of it will be determined.

The changeover between 1st and the 2nd required value can be done via the digital input, terminal X1/14 on the control card. If this input is connected to Ground (X1/10), the 2nd required value will be active.

Possible settings with \uparrow or \downarrow :

OFF	2 nd required value is not active (Using only standard set point)
INT	Internal 2 nd required value, setting according to existing required value in the main menu, but at closed digital input (X1/14).
EXT ADC-I	<p>The 2nd required value is given from the value of a current signal (4-20mA) connected to terminals X1/12, X1/10 (Ground).</p> <p><u>Notice:</u> If the incoming current signal is below 4mA, an error message will be shown on the display and a failure is indicated (failure relay is closed). The failure is also shown at a multi pump layout, but no failure would be indicated (failure relay is not closed) only the master-pump will be exchanged. If the current signal fails at all HYDROVARs, the failure would be indicated also.</p>
EXT ADC-U 0-10V or EXT ADC-U 2-10V	The 2 nd required value is given from the value of a voltage signal (0-10V or 2-10V) connected to terminals X1/13, X1/10 (Ground).

The max. value of the analogue signal is equal to the defined SENSOR RANGE.
(see chapter 9.15)

Setting the 2nd required value:

The active required value is shown in the actual display of the parameter "Required value". If the 2nd required value is enabled (digital input, terminal X1/14, closed), there is shown "Required value 2" in the first line.

The second line will shown the source of the 2nd required value, selected in the parameter CONFIG. REQ VAL.2, and also the actual value of this input as well.

INT: setting according the existing required value in the main menu

EXT: only display of the value of the 2nd analogue input signal.

In case of saving, both required values will be saved automatically.

Press the * button to change to the next parameter

9.20 Configuration of the pump running relay (X2/4-5-6)

RELAY CONFIG.
Run Motor

- Possible selection with ↑ and ↓.
- **Simple Multicontr.** ⇒ Allows to start/stop a fixed speed pump.
 - **Run Motor** ⇒ motor run indication (via the relay)

If you have selected Simple Multicontroller, the following parameters will have new additional functions:

The start level of the lag pump you enter at the parameter "Enable Seg. Ctl.", and the stop value in the parameter "Synchron. Limit". Using the parameter "Stop Delay Fmin." you are able to switch on the lag pump after a selectable delay time.

e.g. if the HYDROVAR controlled pump reaches the start level, the relay will closed -> fixed speed pump switched ON. It will be switched OFF, the output frequency drops below the defined stop level.

Press the * button to change to the next parameter

9.21 Submenu Offset

The 2nd analogue input either could be used as 2nd required value or as the source for a recalculation (offset) of the required value.

S U B M E N U
Offset

Press * for about 3 seconds to enter the submenu
Press the * button shortly to change to the next parameter (-> chapter 9.22)

9.21.1 Source of the Offset input

OFFSET INPUT
Off

Possible settings with ↑ or ↓

OFF	Offset deactivated
EXT ADC-I	Offset will be calculated according to the current input (4-20mA) connected to terminals X1/12 (X1/10=Ground). There is also the possibility to connect a 2 nd actual value sensor to terminals X1/3 (supply for the sensor) and X1/12. <u>Notice:</u> If the incoming offset signal is below 4mA, an error message will be shown on the display and a failure is indicated (failure relay is closed). The failure is also shown at a multi pump layout, but no failure would be indicated (failure relay is not closed) only the master-pump will be exchanged. If the offset signal fails at all HYDROVARs, the failure would be indicated also.
EXT ADC-U 0-10V	Offset will be calculated according to the voltage input (0-10V or 2-10V) connected to terminals X1/13 (X1/10=Ground)
EXT ADC-U 2-10V	

Press the * button to change to the next parameter

9.21.2 1st Offset level

LEVEL 1
XX.X %

The level 1 is the start level of the 1st Offset.
Adjustable between 0 and 100% of the additional analogue input.

Press the * button to change to the next parameter

9.21.3 2nd Offset level

LEVEL 2
XX.X %

The level 2 is the start level of the 2nd Offset.
Adjustable between 0 and 100% of the additional analogue input.

Press the * button to change to the next parameter

9.21.4 Intensity 1

INTENSITY 1
+XX.X %

Only in combination with Level 1!
This is the intensity of the 1st Offset of the required value at the zero point of the second analogue input.
Setting range: -200% up to +200% of the sensor range

Press the * button to change to the next parameter

9.21.5 Intensity 2

INTENSITY 2
+XX.X %

Only in combination with Level 2!
This is the intensity of the 2nd Offset of the required value at the maximum point of the second analogue input.
Setting range: -200% up to +200% of the sensor range

To leave the submenu press * longer than 3 seconds to change to

S U B M E N U
Offset

Press the * button to change to the next parameter

9.21.6 Example for the Offset

SENSOR RANGE: 20mA \triangleq 10 bar
REQUIRED VALUE: 5 bar

LEVEL 1: 30% of the Offset signal
LEVEL 2: 80% of the Offset signal

INTENSITY 1: -100% \triangleq -5 bar (refer to the sensor range)
INTENSITY 2: +20% \triangleq +2 bar (refer to the sensor range)

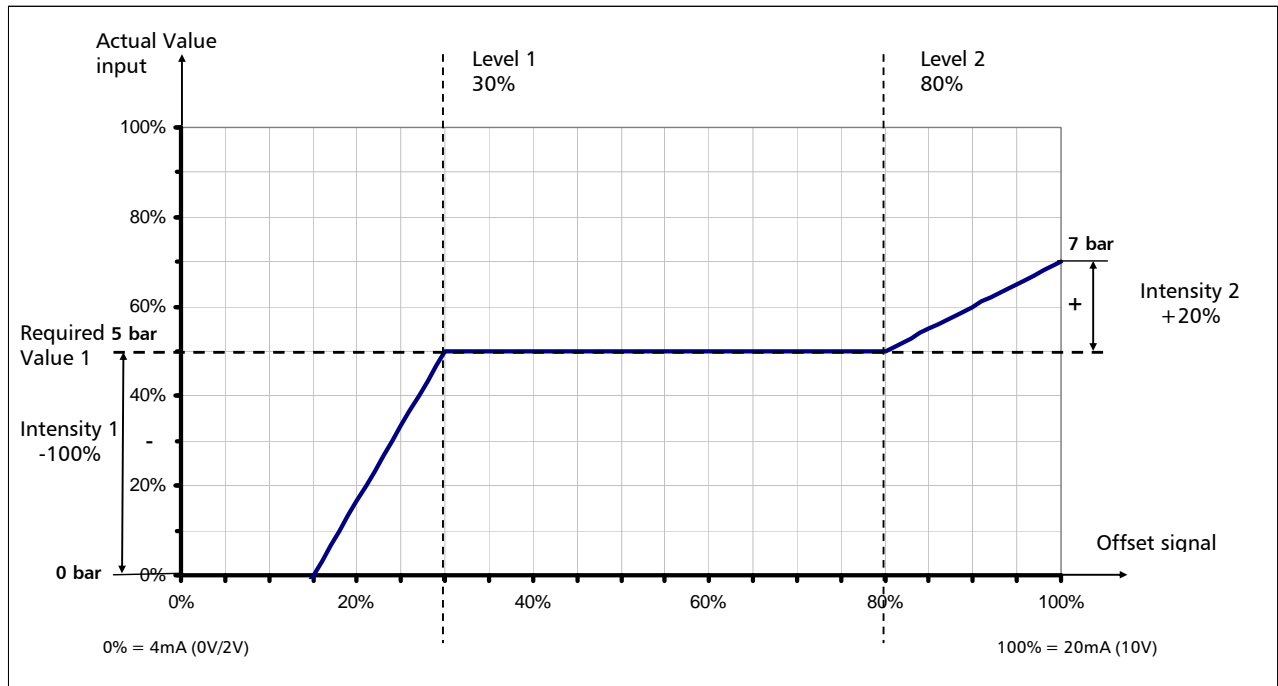

At the parameter *Level 1* you have entered the required value in percent from the Offset signal input (30%), also proceed with the second level (80%).

Intensity one and two are depending on the Sensor range of the external value signal. The Intensity 1 that you have entered is valid till you reach Level 1, after reaching Level 1 the Required Value has no offset.

The standard Required Value will be valid till you reach the Level 2. After reaching level 2, the new value, depending on the Intensity 2, is valid.

Press the * button to change to the next parameter

9.22 Submenu Sequence control

Using the parameters in that submenu all necessary settings can be done for running a multi-pump system. Each parameter within this submenu must be changed only on one HYDROVAR of the system, because it will be transferred via the RS485 interface to each connected HYDROVAR. Up to four pumps can be connected using the integrated RS-485 interface.

S U B M E N U Seq. Control

Press * for about 3 seconds to enter the submenu
 Press the * button shortly to change to the next parameter (-> chapter 9.23)

Application Example:

- 1) Pump 1 reaches fmax (maximum speed)
- 2) Pressure falls and reaches the start-value of the 2nd pump
 (=REQUIRED VALUE-ACTU. VALUE DEC.)
 → Pump 2 is switched on automatically
- 3) The required value is calculated new, after starting the 2nd pump in the following way:
 NEW REQUIRED VALUE = REQUIRED VALUE – ACTU. VALUE DEC. + ACU. VALUE INC.

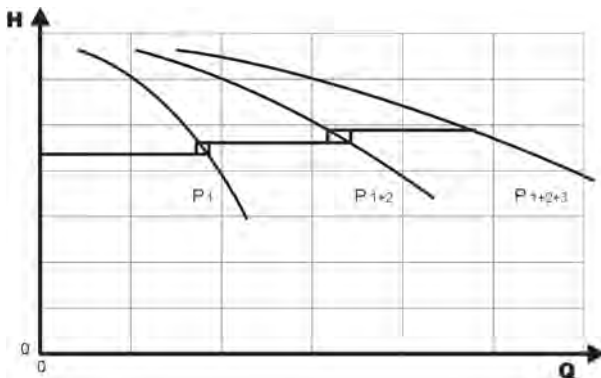

Calculation of the new required value for multi pumps application (Multicontroller Mode):

k ... Number of active pumps (k > 1)

$$p = p_{\text{set}} + (k-1) \cdot [\text{lift value} - \text{fall value}]$$

- Lift value = Fall value ⇒ **Pressure constant** even all pumps are in operation
- Lift value > Fall value ⇒ **Pressure rises** when lag-pump switches on
- Lift value < Fall value ⇒ **Pressure falls** when lag-pump switches on

The following 3 parameters are responsible for switching ON/OFF the lag pumps and for the calculation of the new required value as well.

9.22.1 Lift Value (actual value increase)

ACTU. VALUE INC. 0.35 Bar

Adjustable between 0 to the pre selected Sensor range

Press the * button to change to the next parameter

9.22.2 Fall Value (actual value decrease)

ACTU. VALUE DEC. 0.15 BAR

Adjustable between 0 to the pre selected Sensor range

Press the * button to change to the next parameter

9.22.3 Enable sequence control

With this parameter you can select the desired start-value for the following pumps. If a pump in the system reaches this release-frequency and the system pressure drops below the "Required value" - "actual value decrease", the next pump will start.

ENABLE SEQ. CTL. 48.0 Hz

Adjustable from 0.0 Hz to 70 Hz.

In general this release frequency should be set 1-2 Hz lower than the max. frequency. If the following pump(s) are not necessary to cover a higher demand, but want to be used for automatic change over to provide even wear or in case of a failure, the release frequency must be set higher than the max. frequency.

This parameter is used also to start a fixed speed pump, when Simple Multicontr. is set. When this frequency level is reached, the dry contact of the relay X2/5 – X2/6 will be closed. With the parameter Stop Delay Fmin (chapter 9.11), you could select a delay time.

Press the * button to change to the next parameter

9.22.4 Switch Interval

This parameter allows an automatic change over of the master pump and the following pumps, in order to provide even wear and achieve even operating hours of the pumps.

This is the interval of time after which the starting sequence of the pumps is automatically switched in order to ensure the uniform use of all the pumps available (the interval is based on the operating time of the pumps, MOTOR HOURS parameter).

SWITCH INTERVAL 12 hours

Adjustable between 1 and 100 hours.

If an interval of more than 100 hours is selected, the automatic changeover is disabled. Manual change of the master pump in the 1st display with the ↑ - button.

Press the * button to change to the next parameter

9.22.5 Source of required value

SOURCE REQ. VALUE OFF

By using a 2nd required value in a multi-pump system, there are different options to set the source of this value.

For selecting you have to choose the desired pump-address which should be the source of the required value. Following adjustments are possible: OFF, ADR1, ADR2, ADR3 and ADR4

If an additional analogue input is active, you have to enter the address where this input is connected. If the right address is selected, the additional input is active for the whole system, which means that only one input is necessary also for a multi-pump system.

At active Multicontroller or Synch. Controller mode, the active value (required value 1 or 2) is shown in the centre of the display in the first line of the first window (see chapter 8c).

If "#" is shown in the second line of the display, the pump will work with a required value from another pump in the multi-pump system. On the pump, which is the source of the required value, no "#" is shown.

If the source of the required value is set to "OFF", no 2nd required value is used, or the source for this value is always taken of the actual master.

Press the * button to change to the next parameter

9.22.6 Submenu Synchronous Control

By using the synchronous control all pumps in the system maintain the set pressure by running on the same frequency. The 2nd pump starts, when the 1st pump reaches the release frequency (ENABLE SEQ. CONTR.) and both pumps will run synchronously. The follow-up pump will be stopped, when the frequency drops below the set SYNCHRON. LIMIT. This function creates a hysteresis effect which prevents the follow-up against a frequent on/off operation.

S U B M E N U Synch. Control

Press * for about 3 seconds to enter the submenu
Press the * button shortly to change to the next parameter (-> chapter 9.22.7)

9.22.6.1 Synchronous Limit

Tip to find out the right Setting:

1. Start the first pump in JOG Mode (1st Window in the submenu), increase the frequency till you reach the required value. Check the frequency ($= f_0$) at zero consumption
2. Set the synchronous limit ($f_0 + 2..3$ Hz)
3. Set the synchronous window between 1 or 2 Hz (depending on the pump curve and set point).

SYNCHRON. LIMIT 0,0 Hz

Frequency limit adjustable between 0 Hz and the set maximum frequency.

Switch off limit of the first follow-up pump. So if the frequency of both pumps is lower than this selected value, the first follow-up pump will be switched off.

This parameter is also used for the stop value using an external fixed speed pump with activated Simple Multicontroller in the parameter CONFIGURATION RELAY.

Press the * button to change to the next parameter

9.22.6.2 Synchronous Window

SYNCHRON-WINDOW 2.0 Hz

Adjustable between 0...10 Hz
Frequency limit for switching off the next follow-up pump.

Switching of the 3rd pump:

All 3 pumps are running with an output frequency < SYNCHRON. LIMIT + SYNCHRON-WINDOW

Switching of the 4th pump:

All 4 pumps are running with an output frequency < SYNCHRON. LIMIT + 2xSYNCHRON-WINDOW

To leave the submenu press * longer than 3 seconds to change to

S U B M E N U
Synch. Control

Press the * button to change to the next parameter

9.22.7 Pump status indication

PUMP – SEQUENCY
Adr1 disabled

Shows the status of the individual HYDROVAR in a multipump system (adjustable between addresses 1 to 4)

The following diagnosis parameters can be also be read in this display window:

AdrX *	Address of the pump that is being read ("*" is shown for the address of the current used pump)
hold Px	Pump is stopped by the system (external on/off closed)
run Px	Pump is running
stop Px	Pump is stopped, because $f <$ start frequency of the previous pump
disabled	Pump not ready to start (external on/off opened, manually stopped)
Error	HYDROVAR error
Fault	Polling failure (RS-485 interface connection wrong or not connected)
detected	Polling successful (RS-485)
Adr5	To check the communication between the HYDROVAR and a connected external unit. (fault / detected)

X ... indicates the selected pump (1-4)

Press the * button to change to the next parameter

9.22.8 Busarbit-Diag. - Counter for interface communication problems

BUSARBIT-DIAG.
0

Shows the number of errors happened during the communication attempts on the RS-485 interface.

At rising values, a malfunction of the RS-485 interface could be possible.

To leave the submenu press * longer than 3 seconds to change to

S U B M E N U
Seq. Control

Press the * button to change to the next parameter

9.23 Submenu - RS 485 Interface

S U B M E N U RS 485-Interface

Press * for about 3 seconds to enter the submenu
Press the * button shortly to change to the next parameter (-> chapter 9.24)

9.23.1 Pump Address

PUMP-ADDRESS OFF

If only one pump is used, the setting remains OFF.

If several pumps are connected via the RS-485 interface (max. 4) each pump must be allocated its own pump-address number (1-4). Address 5 is reserved for an external control device.

Each address may only be used once!

Press the * button to change to the next parameter

9.23.2 ADC Reference

ADC REFERENCE Local

Reference for the local ADC (Analogue/Digital-Converter) or SIO (RS485 interface).

Possible Settings:

LOCAL: Actual value sensor (Terminal X1/ 1-2)

REMOTE: Actual value via RS-485 (Terminal X5 or X6/ 1-2-3)

To leave the submenu press * longer than 3 seconds to change to

S U B M E N U RS 485-Interface

Press the * button to change to the next parameter

9.24 Frequency Lifting

Control according to a system curve (increase of the set pressure, depending upon the delivery rate or speed).

FREQU. – LIFTING
30.0 Hz

Adjustable between 6 Hz and the set MAXIMUM FREQUENCY.

The setting determines the output-frequency where the set pressure starts to be increased. The right setting should be the frequency when the pump reaches the set pressure at zero flow. (Can be found out by using the JOG MODE)

Press the * button to change to the next parameter

9.25 Lift- Amount (Intensity)

LIFT – AMOUNT
0.0 %

Adjustable from 0% to 199,9%

This value states how much the set value should be continually increased, till the maximum speed (maximum volume) is reached.

Application example:

- 1) Enter the set pressure (see main menu)
- 2) Find out the frequency where set pressure is reached at zero demand (see Jog Mode) and enter this value in parameter FREQU. LIFTING
- 3) Set desired lift at maximum speed in % of the set pressure in the parameter LIFT-AMOUNT.

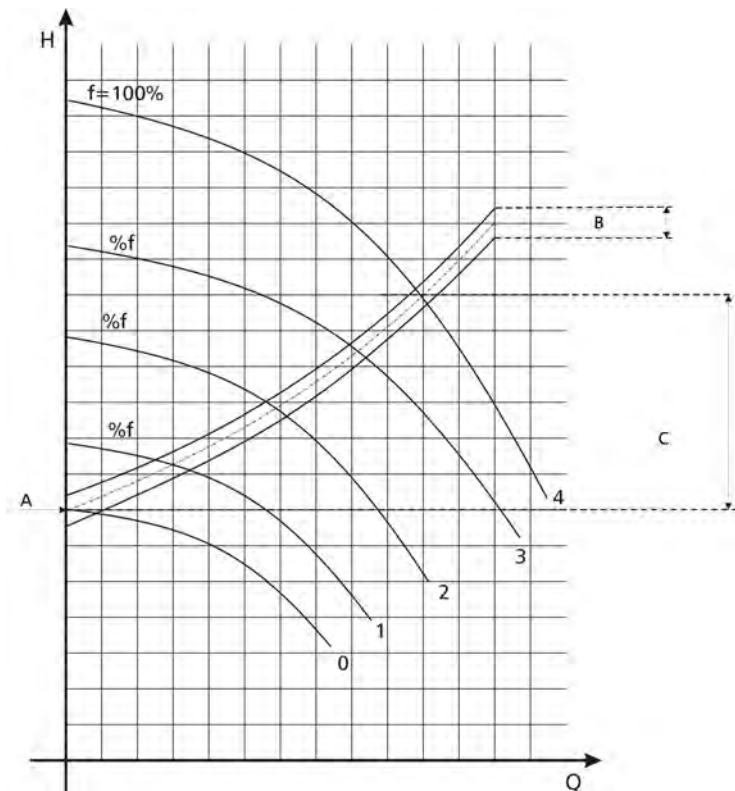

A...set pressure
B... window
C... lift intensity in % of set pressure

Press the * button to change to the next parameter

9.26 Analogue - Output

ANALOG - OUT Actual value

Analogue output 0 – 10 VDC = 0 - 100% (max. 2 mA)
(at terminal X1/11, X2/10=ground)

Possible settings:

- ◆ **Actual value** (signal at terminal X1/2)
- ◆ **Output frequency** (0 - f_{max})

Press the * button to change to the next parameter

9.27 Dimension Unit

DIMENSION UNIT Bar

Can be changed with ↑ or ↓.

Adjustable units: bar, psi, m³/h, g/min, ft, mH₂O, % or without unit

By changing the DIMENSION UNIT, the SENSOR RANGE (see chapter 9.15) will be automatically calculated according to the new unit! Therefore after changing the UNIT, you have to check the setting of the SENSOR RANGE!

Press the * button to change to the next parameter

9.28 Automatic test run

TEST RUN after 100 h.

Adjustable between 10...100 operating hours.

The test run starts the pump at the set time after the last stop for 20 seconds to a speed of 30 Hz.

Deactivating test run:

- Set 100 hours -> keep button ↑ depressed, shortly press the button ↓ in addition -> "deactivated" appears on the display
- To reactivate the test run, set the desired hours using the ↓ button.

The test run is only active, when the pump is stopped and external on/off is closed!

Press the * button to change to the next parameter

9.29 Submenu for manual test run

S U B M E N U
TEST RUN man.

Press * for about 3 seconds to enter the submenu
Press the * button shortly to change to the next parameter (-> chapter 9.30)

9.29.1 Activate manual test run

TEST RUN man.
↑ + ↓

By simultaneously pressing ↑ + ↓ a test run will be started.

The HYDROVAR speeds up to the test frequency with Ramp1 and then decreases the speed till stop with Ramp2.

Press the * button to change to the next parameter

9.29.2 Test Frequency

TEST-FREQUENCY
30.0 Hz

Frequency for manual test run.
Can be set from 6.0 Hz up to 70,0 Hz

Press the * button to change to the next parameter

9.29.3 Boost for manual test run

BOOST TEST-RUN
10.0 %.

Setting of the motor starting voltage in % of rated input voltage (0 - 25% of maximum input voltage is possible)

To leave the submenu press * longer than 3 seconds to change to

S U B M E N U
TEST RUN man.

Press the * button to change to the next parameter

9.30 Submenu - Error

S U B M E N U
E R R O R S

Press * for about 3 seconds to enter the submenu
Press the * button shortly to change to the next
parameter (-> chapter 9.31)

9.30.1 Conveyor Limit

CONVEYOR-LIMIT
disabled

Adjustable between 0.00 and max. SENSOR RANGE.

- To disable the conveyor limit, press ↓ till "disabled" is shown on the display. (0bar)
- An adjusted value >0 has to be reached till the programmed "DELAY TIME".
- If this value can't be reached, the HYDROVAR stops and the failure "VAL. RANGE CONTR." will be indicated.

Press the * button to change to the next parameter

9.30.2 Delay Time

DELAY TIME
2 Sec

Adjustable between 0...100 Sec.

Delay time to switch-off the HYDROVAR in case the actual value drops below the conveyor limit or a connected external low water protection opens the terminals X1/6-X1/7.

Notice: The Conveyor Limit function is also active during the start period of the pump!
Therefore the delay time has to be set higher than the duration till the pump reaches this value also during the start of the pump!

Press the * button to change to the next parameter

9.30.3 Automatic Error reset

ERROR – RESET
disabled

This parameter allows an automatic restart for 5 times in case of a failure. To activate this function a certain delay-time (0-250sec) has to be selected by pressing the ↑ button. (not for internal "error 1-9")

After the 5th restart the HYDROVAR will shut off definitely and an error message is shown. (The internal counter of the automatic error reset would be decreased after each operating hour, so if an error could be reset after 3 restarts, there are 3 restarts possible after an hour, 4 after two hours and 5 automatic restarts after 3 operating hours.)

To deactivate this parameter press the ↓ button until "disabled" appears.

Press the * button to change to the next parameter

9.30.4 Clear Errors

CLEAR ERRORS
0000

The error memory can be deleted by entering a password.

For more information contact your distributor!

To leave the submenu press * longer than 3 seconds to change to

S U B M E N U
E R R O R S

Press the * button to change to the next parameter

9.31 Operating Hours

OPERATING HOURS 0000 h.

Total time the HYDROVAR is connected to the power supply. Reset: press ↑ and ↓ together, till "TIMER-RESET" appears.

In parallel, the TOTAL RUN TIME of the motor, in the main menu would be reset.

Press the * button to change to the next parameter

9.32 Display – Contrast

DISP. CONTRAST 50 %

Can be adjusted between 10 and 100% for improved clarity of the display, depending on the installation position.

Press the * button to change to the next parameter

9.33 Set Password

SET PASSWORD 0066

The pre-set password (0066) can be changed if necessary. Set Password by pressing ↑ or ↓

If the password will be modified, it is recommended to make some notes about the new password.

Press the * button to change to the next parameter

9.34 Lock Function

LOCK FUNCTION OFF

Possible settings with ↑ or ↓

OFF: All parameters in the main menu can be changed without the need of a password.

ON: If the LOCK FUNCTION is activated, it's not possible to make any changes in the main menu. The HYDROVAR can be just started or stopped by using the buttons ↑ and ↓. In order to change the set value, the LOCK FUNCTION must be reset to OFF.

Press the * button to change to the next parameter

9.35 Internal Heater

HEATING ON

Internal heating during standstill to prevent condensation in the HYDROVAR

If "ON" is selected (**should be the general configuration**) a heating resistance (approx. 10 watt) is switched on, when the motor is at a standstill and the supply of the HYDROVAR is O.K.

Notice: If the HYDROVAR is cut from the supply the internal heater doesn't work! So if the HYDROVAR isn't used for a longer time (e.g. winter season) it shouldn't be disconnected from the power-supply.

Press the * button to change to the next parameter

9.36 Setting Default Values

S U B M E N U
DEFAULT VALUES

Press * for about 3 seconds to enter the submenu
Press the * button shortly to change to the next
parameter (-> chapter 9.37)

You reset all settings to the default settings for two different areas (EUROPE or USA).

If you suspect you made a mistake by entering parameter-settings but are unable to identify the location, you can start again from the beginning by reloading the factory settings.

9.36.1 Default Values Europe

DEFAULT EUROPE
↑ + ↓

Load the DEFAULT – PARAMETERS for Europe by
pressing the ↑ + ↓ for approx. 5 seconds.
(max. frequency 50 Hz, display unit = bar)

Press the * button to change to the next parameter

9.36.2 Default Values USA

DEFAULT USA
↑ + ↓

Load the DEFAULT – PARAMETER for the USA by
pressing the ↑ + ↓ for approx. 5 seconds.
(max. frequency 60 Hz, display unit = psi)

IMPORTANT! After reloading the default settings the display is flashing. To deactivate the flashing you have to save this change (see next parameter).

To leave the submenu press * longer than 3 seconds and change to

S U B M E N U
DEFAULT VALUES

Press the * button to change to the next parameter

9.37 Saving

SAVE ???
↑ + ↓

All values must be saved (stored in an EEPROM) after
changing.

If they aren't saved, all changes will be lost in case of a power failure!

Saving: Press ↑ + ↓ till the message "SAVED" is shown on the display.

After saving, the display changes automatically to the 1st display after a few seconds.

10 Error Signals

The active Error messages are shown in the selected language, but the last 5 Error messages stored in the Error memory (main menu) are displayed in English language only!

After the cause has been remedied, the error can be reset by cutting off the power supply for >60 seconds, or pressing all three buttons (↑, ↓ and *) together for about 5 seconds.

All error signals are indicated at terminal X2/1-2-3 (failure relay).

If no Error is active, the relay switches on and terminals X2/2 and X2/3 are closed.

NOTICE: If "AUTO – START" is ON and automatic "ERROR-RESET" is enabled, the HYDROVAR can start again automatically after a power failure.

Error-picture	Probability cause	Solution
No error-message on the display - No red LED		
no AUTOSTART after power failure	Parameter AUTOSTART is set to "OFF"	Check Parameter AUTOSTART
Display shows INVERTER LOCKED / ENABLE INVERTER	external ON/OFF contact is opened	check if switch or external contact is closed or bridge X1/4 and X1/5
EXT ADC-I <4mA is blinking on the display	Either 2 nd Required Value or OFFSET is active but no signal (4-20mA) connected	check external analogue signal (on terminals X1/10-12)
No operation even system pressure < set pressure	Pressure higher than the start value, regulation mode isn't set to NORMAL.	check parameter START VALUE and/or REGULATION MODE

Error-message on the Display - red LED on		
Lack of water	Low water contact is open	<ul style="list-style-type: none"> • protection of incoming pressure or min. level to less • bridge X1/6-7, if there is no ext. low water protection • adjust Parameter DELAY TIME if the failure happens only for short time
Conveyer Limit	adjustable value of Parameter CONVEYER LIMIT is not reached	<ul style="list-style-type: none"> • check booster unit, adjust Parameter DELAY TIME • Parameter ERROR RESET set to ON, to enable 5 restarts (e.g. in empty system)

Motor overheat	PTC in the conduit box has reached its release temperature	<ul style="list-style-type: none"> • close X1/8 - 9 if there is no PTC available (e.g. submersible pumps) • no proper motor cooling • outside temperature too high • MOTOR OVERLOAD • check star/delta connection
Inverter overheat	too high temperature inside the HYDROVAR	<ul style="list-style-type: none"> • no proper cooling • contamination of the motor vents • ambient temperature too high
Over voltage	DC voltage of the HYDROVAR too high	<ul style="list-style-type: none"> • Parameter Ramp 2 too fast • Power supply too high • Voltage peaks too high (Solution: Line filters, Line inductance, RC-Element)
Under voltage	DC voltage of the HYDROVAR too low	<ul style="list-style-type: none"> • supply voltage too low • phase failure at the input • asymmetry of the Phases
Overloaded (shown on the display, but HYDROVAR keeps on running)	Power limit of the HYDROVAR is reached	<ul style="list-style-type: none"> • check Parameter settings, and operation point of the motor • input power too high • check characteristics of the HYDROVAR
Overload	Power limit of the HYDROVAR is exceeded	<ul style="list-style-type: none"> • check Parameter Ramp 1/2 (too short) and BOOST (too low) • check motor connection (star/delta) and cable • Pump blocked • Motor turns in the wrong direction before running (Non return-valve defect) • Not allowed operation point or Parameter Max. frequency too high • check Parameter BOOST in the menu MANUAL TEST RUN
Output short	Current rise at the output too high	<ul style="list-style-type: none"> • check connection-terminals of the HYDROVAR • check the connection-terminal of the motor • check the motor-cable • check the windings of the motor
Act. Value Sensor	Data signal on terminals X1/2 < 4mA	<ul style="list-style-type: none"> • ACTUAL VALUE signal (pressure transducer) faulty • wrong connection • Sensor (Transducer) fault • faulty Transducer cable

To quit the following errors you have to cut the power supply for >30 seconds. If the error signal should appear again, contact customer service and provide a detailed description of the error.

Internal errors Error-message on the Display - red LED on		
ERROR 1	EEPROM-ERROR (corresponding data block malfunction)	Reset - after repeated error-message ⇒ change control card
ERROR 2	Security error / Software protection error	Reset - after repeated error-message ⇒ change control card
ERROR 3	RAM-error	Reset - after repeated error-message ⇒ change control card
ERROR 4	Button error (e.g.: jammed key)	<ul style="list-style-type: none"> • check push buttons, • Display-board may be defect
ERROR 5	EPROM-error	Reset - after repeated error-message ⇒ change control card
ERROR 6	Program error: Watchdog error	Reset - after repeated error-message ⇒ change control card
ERROR 7	Program error: Processor pulse error	Reset - after repeated error-message ⇒ change control card
ERROR 8	Program error: invalid processor command	<ul style="list-style-type: none"> • check the installation of the cables, connection of the screen and potential equalization • check earth/ground • install additional inductances for the signal-cables (e.g. ferrites)
ERROR 9	Counter of operation time	Reset - after repeated error-message ⇒ change control card

Examples

Booster unit

Problem: no stop of the HYDROVAR	
Parts to check	Solution
<ul style="list-style-type: none"> • existing demand • non return valve is not closed • pre charge pressure in the pressure tank • no correct settings of WINDOW and RAMPHYSTERESIS • shut down RAMP too slow • suction line too long 	<ul style="list-style-type: none"> • check pipes and valves • change non return valve • adjust according the diagram • set WINDOW (ca.10%) and RAMPHYSTERESIS (80-50%) • set RAMP 2 to 4...15 sec. • the MINIMUM FREQUENCY should be activated for pressure increase at 0 demand

Control on constant flow

Problem: control fluctuations	
Parts to check	Solution
control characteristics are set to low	enlarger WINDOW and RAMPHYSTERESIS to 99% to control with RAMP 3 and 4

Circulating pump

Problem: oscillation of the motor speed	
Parts to check	Solution
control settings too fast	<ul style="list-style-type: none"> • increase RAMP 3 and 4: 100...200sec • WINDOW (ca.20%) and RAMPHYSTERESIS (ca.99%)
Problem: ACTUAL VALUE can't be hold	
Parts to check	Solution
Ramphysteresis too big	RAMPHYSTERESIS: 90-99%

Submersible pumps

Problem:	motor cables are too long
Solution:	reduce SWITCHING FREQUENCY, BOOST: 10-20%

General

Problem:	pressure fluctuations, analogue signal not constant
Solution:	<ul style="list-style-type: none"> • check cables and connection of the screen • check earth connection of the Transmitter • use screened cables

11 RS 485 - Interface

Standardised Bus-Interface for communication between the HYDROVAR and/or an overruling external control system.

The data protocol complies with ISO 1745 for RS 485 interfaces and contains the following configurations:

Data rate: 9600 Baud (1 Start Bit, 8 Data, 1 Stop Bit)

An interface inverter RS 232/RS 485 is necessary in case communication with a 24V interface of a PC or another external control system is wanted.

The whole interface protocol can be obtained upon request.

12 Auxiliary Texts

These are available for all parameters. To call them up press the buttons * + ↑. Each auxiliary text then appears as "running text" in the second line of the window.

13 Maintenance

The HYDROVAR does not require special maintenance.

However, the cooling fan and the vents should be freed of dust occasionally. Also the temperature around the unit should be checked from time to time.

All modifications must be done by qualified technicians! For mounting and repairs at the HYDROVAR, qualified service technicians are available.

Demounting:

The HYDROVAR must be disconnected from the power supply before any work can be carried out. Look at the pump- and motor-instruction.

Notes:

When replacing the control card in a plant with more than one pump, ensure that the software / hardware is compatible with all other control cards.

For further information, please ask your distributor!

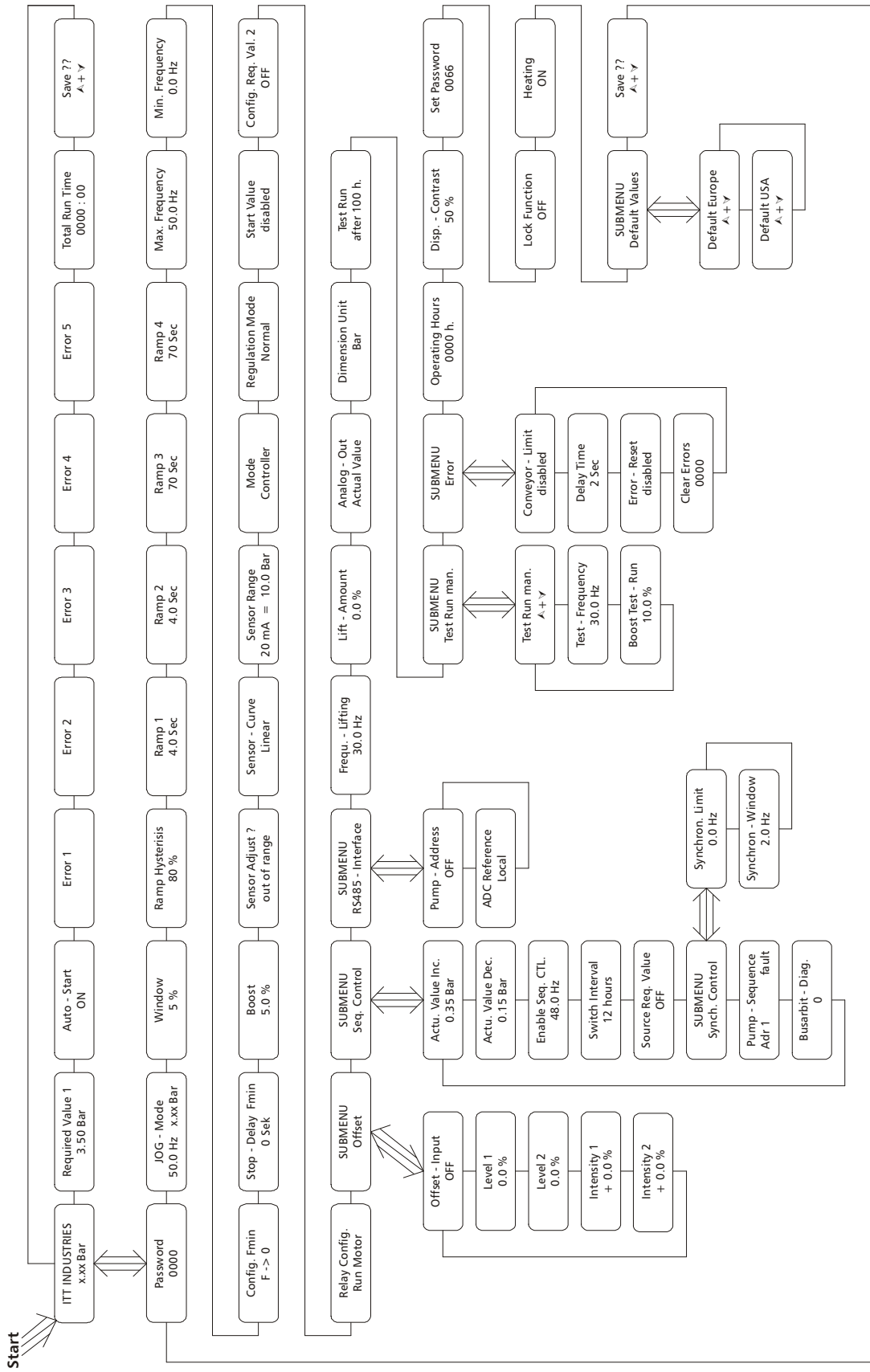

Notes:

“ITT” and „Engineered for life“ are registered trademarks of ITT Industries, Inc. All other trademarks or registered trademarks are property of their respective owners.



XYLEM WATER SOLUTIONS AUSTRIA GMBH
Ernst-Vogel Strasse 2
2000 Stockerau
Österreich
Telefon: +43 (0) 2266 / 604
Telefax: +43 (0) 2266 / 65311
e-mail: info.austria@xyleminc.com
web: www.xylemaustria.com

Xylem Water Solutions Austria GmbH reserves the right to make modifications without prior notice.
© 2012 Xylem, Inc