

# CD500M Heavy Duty Dri-Prime® Pump

The Godwin Dri-Prime CD500M Heavy Duty pump offers flow rates to 16120 USGPM and has the capability of handling solids up to 3.1" in diameter.

The CD500M Heavy Duty is able to automatically prime to 28' of suction lift from dry. Automatic or manual starting/stopping available through integral mounted control panel or optional wireless-remote access.

Indefinite dry-running is no problem due to the unique Godwin liquid bath mechanical seal design. Solids handling, dry-running, and portability make the CD500M Heavy Duty the perfect choice for dewatering and bypass applications.



## Features and Benefits

- Simple maintenance normally limited to checking fluid levels and filters.
- Dri-Prime (continuously operated Venturi air ejector priming device) requiring no periodic adjustment. Optional compressor clutch available.
- Extensive application flexibility handling sewage, slurries, and liquids with solids up to 3.1" in diameter.
- Dry-running high pressure liquid bath mechanical seal with high abrasion resistant solid tungsten faces.
- Pedestal-mounted centrifugal pump with Dri-Prime system coupled to a diesel engine or electric motor.
- All cast iron construction (stainless steel construction option available) with cast steel impeller.
- Plated skid with integrated 570 US Gal fuel tank designed for rough terrain in mines and quarries.
- Standard engine Caterpillar C15 (T3 Flex). Also available with Caterpillar C18 (T3 Flex).

## Specifications

Suction connection	24" 125# ANSI B16.1
Delivery connection	18" 125# ANSI B16.1
Max capacity	16120 USGPM †
Max solids handling	3.1"
Max impeller diameter	24.0"
Max operating temp	176°F*
Max pressure	103 psi
Max suction pressure	73 psi
Max casing pressure	155 psi
Max operating speed	1200 rpm

\* Please contact our office for applications in excess of 176°F.

† Larger diameter pipes may be required for maximum flows.

## Performance Curve

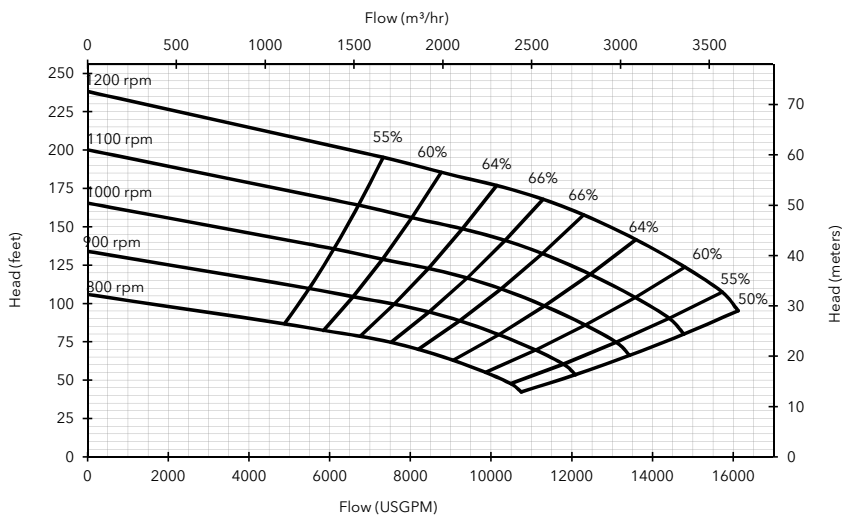

### Engine option 1

Caterpillar C15 (T3 Flex), 475 HP @ 1800 rpm

Impeller diameter 24.0"

Pump speed 1050 rpm driven by 1.7:1 gearbox

#### Suction Lift Table

Total Suction Head (feet)	Total Delivery Head (feet)				
	66	105	111	117	123
	Output (USGPM)				
10	13449	10717	10087	8405	7145
15	13028	10129	9456	7565	6724
20	10717	9666	9288	7061	6304
25	6619	5884	-	-	-

Fuel capacity: 570 US Gal

Max Fuel consumption @ 1800 rpm: 23.7 US Gal/hr

Max Fuel consumption @ 1600 rpm: 23.0 US Gal/hr

Weight (Dry): 27,650 lbs

Weight (Wet): 30,260 lbs

Dim.: (L) 240" x (W) 101" x (H) 92"

Performance data provided in tables is based on water tests at sea level and 20°C ambient. All information is approximate and for general guidance only. Please contact the factory or office for further details.

## Materials

Pump casing & suction cover	Cast iron BS EN 1561 - 1997
Wearplates	Cast iron BS EN 1561 - 1997
Pump Shaft	Carbon steel BS 970 - 1991 817M40T
Impeller	Cast Steel BS3100 A5 Hardness to 200 HB Brinell
Non-return valve body	Cast iron BS EN 1561 - 1997
Mechanical seal	Double Mech seal; Tungsten carbide face; Viton elastomers; Stainless steel body

### Engine option 2

Caterpillar C18 (T3 Flex), 700 HP @ 1800 rpm

Impeller diameter 24.0"

Pump speed 1200 rpm driven by 1.5:1 gearbox

#### Suction Lift Table

Total Suction Head (feet)	Total Delivery Head (feet)				
	99	150	158	166	174
	Output (USGPM)				
10	15370	12248	11528	9606	8165
15	14890	11576	10807	8646	7685
20	12248	11047	10615	8069	7205
25	7565	6724	-	-	-

Fuel capacity: 570 US Gal

Max Fuel consumption @ 1800 rpm: 36.2 US Gal/hr

Max Fuel consumption @ 1600 rpm: 34.0 US Gal/hr

Weight (Dry): 28,050 lbs

Weight (Wet): 30,660 lbs

Dim.: (L) 240" x (W) 101" x (H) 97"

Performance data provided in tables is based on water tests at sea level and 20°C ambient. All information is approximate and for general guidance only. Please contact the factory or office for further details.

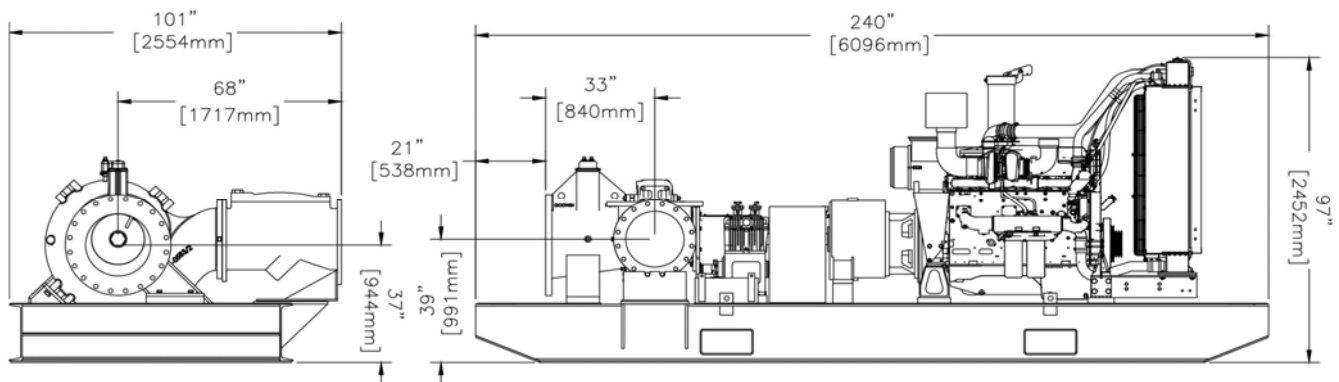

84 Floodgate Road  
Bridgeport, NJ 08014 USA  
(856) 467-3636 . Fax (856) 467-4841  
Email: sales@godwinpumps.com

Reference number : 95-1023-3000  
Date of issue : February 26, 2014  
Issue : 1

[www.godwinpumps.com](http://www.godwinpumps.com)