

60Hz

# Flygt BIBO 2860 SH

SOME THINGS MAKE A LASTING IMPRESSION

For decades whenever a dewatering challenge seemed too tough or too harsh, the answer has been simple, Flygt BIBO. So how do you improve upon a legend? Simple, we created a new one.

It still has the iconic look; a shape that means stability and robustness. We took our proven hydraulic design and merged it with features that once set the standard in dewatering pumping. For mining, quarrying, construction and tunneling, Flygt BIBO, still a choice you never regret.

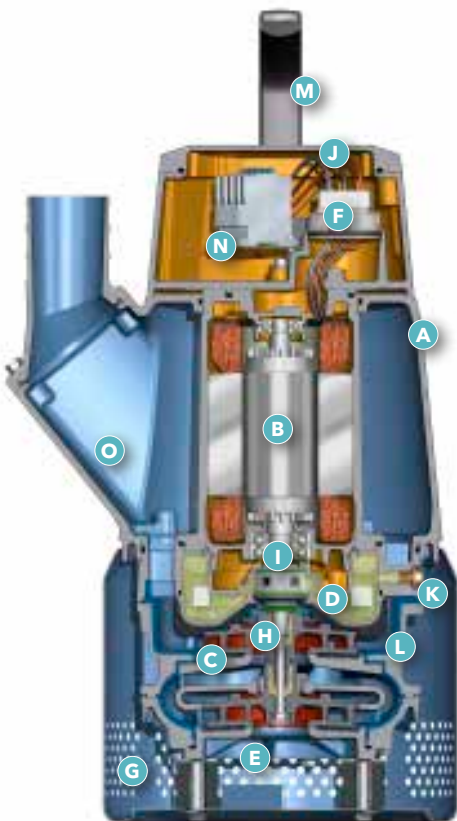

- A Air valve**  
The cooler the motor, the better the performance.
- B Class H motor**
- C Dura-Spin™**  
The unique closed impeller and the suction cover which reduces wear.
- D Spin-Out™**  
Protects the outer seal from abrasive particles.
- E Hard-Iron™ twin impellers and suction cover.**
- F Sealed off terminal board**
- G Strainer bottom with shock absorbers**
- H Single impeller-adjustment screw**
- I Plug-in™ seal with aluminum housing**
- J Inspection cover**
- K External inspection and oil plugs**
- L PolyLife™ coated wear parts**
- M Handle with adjustable height**
- N Less risk of cable damage with a protected cable entry**
- O Wide base and low discharge**



**FLYGT**  
a xylem brand

## Performance

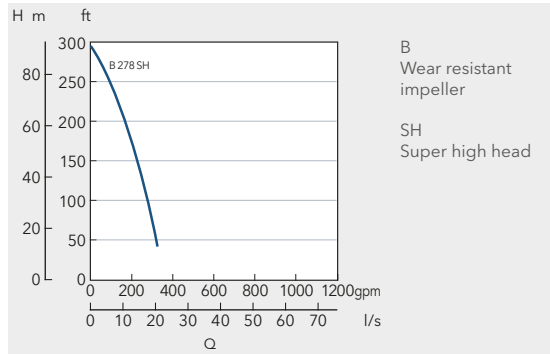

## Rating

15.0 hp (11.2 kW) / 3-phase / 3,465 rpm

Voltage V	Rated current A	Starting current A
200 D	40	250
220 D	37	222
220 Y parallel	37	213
230 D	35	233
230 Y parallel	35	224
240 D	35	245
240 Y parallel	35	235
380 D	21	128
380 Y parallel	21	128
400 D	20	136
400 Y parallel	21	135
440 D	19	129
440 D serial	18	111
440 Y serial	18	107
460 D	19	135
460 D serial	18	117
460 Y serial	18	112
480 D	20	142
480 Y serial	17	117
575 D	14	96
600 D	14	101

## Denomination

Product code	2860.180
Installation	Portable
Discharge connection	4"/6"
Impeller characteristics	Super high head (SH) Wear resistant impeller (B) with Dura-Spin™

## Process data

Liquid temperature	max 104°F (40°C), standard
Depth of immersion	max 65 feet (20 m)
Liquid density	9.2 lb. per US gal. (1100 kg/m <sup>3</sup> )
Strainer hole dimension	ø 0.39" (10.0 mm)
The pH of the pumped liquid	pH 5-8

## Motor data

Frequency	60 Hz
Insulation class	H, 360°F (180°C)
Voltage variation	max ± 10% - continuously running max ± 10% - intermittent running
Voltage imbalance	max 2% - between phases max 30 - No. of starts/hour

## Monitoring equipment

Thermal contacts	284°F (140°C)
------------------	---------------

## Cables

SUBCAB®	SUBCAB® Submersible cable
---------	---------------------------

## Materials

Outer casing	Aluminium
Impeller	Hard-Iron®
Wear parts	PolyLife/Nitrile rubber/Hard-Iron®
Stator housing	Aluminum
Strainer	Stainless steel
Shaft	Stainless steel
O-rings	Nitrile rubber
Discharge connection	Aluminium

## Mechanical face seals

Inner Active Seal™	Aluminium oxide/Tungsten carbide
Outer	Tungsten carbide/Tungsten carbide

## Weight and dimensions

Weight (excl. cable)	234 lbs. (106 Kg)
Height	38.4" (975 mm)
Width	ø 16.7" (425 mm)

## Options

Warm liquid version	Warm liquid version max 158°F (70°C)
Quick couplings	
Starters	

## Accessories

Tandem connections, hose connections. Electrical accessories such as pump controllers, control panels and monitoring relays. Zinc anodes.
---



XYLEM  
Gesällvägen 33  
174 87 Sundbyberg, Sweden  
Tel +46 8 475 60 00  
www.xyleminc.com  
www.flygt.com

